

GENERAC[®]

MAGNUM

Owner's Manual
Light Tower

MLT6SC

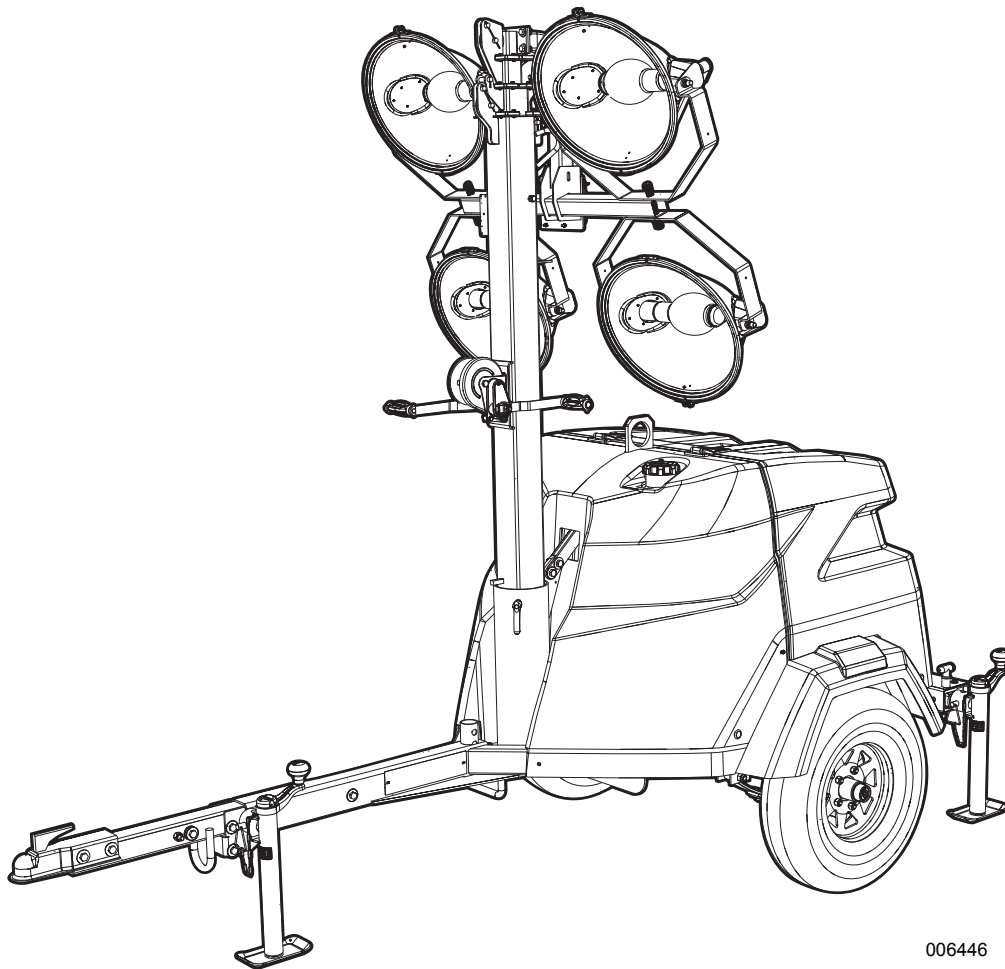

006446

SAVE THIS MANUAL FOR FUTURE REFERENCE

Use this page to record important information about your Light Tower

Unit Model Number	MLT6SC
Unit Serial Number	
Engine Model Number	C1.1-EJ501-2055
Engine Serial Number	
Generator Model Number	201CSA5412
Generator Serial Number	

Record the information found on your unit data label on this page. See [Unit Serial Number Locations](#).

Engine and generator serial numbers are located on separate data plates affixed to the engine and generator respectively. When contacting a Generac Mobile Products Authorized Service Dealer (GMP ASD) about parts and service, always provide the unit model and serial number.

Operation and Maintenance: Proper maintenance and care of the light tower ensures a minimum number of problems and keeps operating expenses at a minimum. It is the operator's responsibility to perform all safety checks, to verify that all maintenance for safe operation is performed promptly, and to have the equipment checked periodically by a Generac Mobile Products Authorized Dealer. Normal maintenance, service and replacement of parts are the responsibility of the owner/operator and, as such, are not considered defects in materials or workmanship within the terms of the warranty. Individual operating habits and usage may contribute to the need for additional maintenance or service.

WARNING

Operating, servicing and maintaining this equipment can expose you to chemicals including engine exhaust, carbon monoxide, phthalates, and lead, which are known to the State of California to cause cancer and birth defects or other reproductive harm. To minimize exposure, avoid breathing exhaust, do not idle the engine except as necessary, service your equipment in a well-ventilated area and wear gloves or wash your hands frequently when servicing your equipment.

For more information go to

www.P65Warnings.ca.gov

(000393)

WARNING

Breathing diesel engine exhaust exposes you to chemicals known to the State of California to cause cancer and birth defects or other reproductive harm.

- Always start and operate the engine in a well-ventilated area.
- If in an enclosed area, vent the exhaust to the outside.
- Do not modify or tamper with the exhaust system.
- Do not idle the engine except as necessary.

For more information go to

www.P65Warnings.ca.gov/diesel

(000394)

Table of Contents

Section 1: Introduction and Safety

Introduction	1
Read This Manual Thoroughly	1
How to Obtain Service	1
Safety Rules	1
General Hazards	2
Explosion and Fire Hazards	2
Trailer Hazards	2
Electrical Hazards	3
Battery Hazards	3
Fuel Hazards	4
Engine Safety	4
Operating Safety	4
Positioning the Unit	4
Starting the Unit	4
Raising and Lowering the Mast	5
Service Safety	5
Towing Safety	6
Hitch and Coupling	6
Running Lights	6
Wheels and Tires	6
Safe Towing Techniques	6
Reporting Trailer Safety Defects	6
Safety and Operating Decals	7

Section 2: General Information

Specifications	11
Unit Serial Number Locations	12
Trailer Tongue Storage and Tow Positions	13
Place Trailer Tongue in Tow Position	13
Place Trailer Tongue in Storage Position	14
Unit Dimensions	15
Component Locations	16
Control Panel	18
Control Panel Features and Functions	18
Power Zone—DLA (If Equipped)	19
Controller Features and Functions	19
Operator Screens	20

Section 3: Operation

Light Tower Setup	25
Prestart Checklist	26
Raising the Mast—Manual Winch	26
Raising the Mast—Electric Winch (If Equipped)	27
Starting the Unit	28
Preparing for Start-Up (with Power Zone Controller, If Equipped)	29
Select AUTO or MANUAL Mode	29
Manually Starting the Unit	29
Light Operation	29
Light Operation (With Power Zone Controller, If Equipped)	30
Engine Derating	30
Wet Stacking	30
Dusk to Dawn Sensor	31
Customer Convenience Outlets	31
Shutting Down the Unit	31
Shutting Down the Unit (with Power Zone Controller, If Equipped)	31
Automatic Shutdown	31
Lower Radiator Hose Heater (If Equipped)	31
Tandem Tow (If Equipped)	32
Telemetry (If Equipped)	32
Spark Arrester (If Equipped)	32
Lowering the Mast—Manual Winch	32
Lowering the Mast—Electric Winch (If Equipped)	33
Manually Lowering the Mast	33
Towing the Unit	33
Lifting the Unit	34
Tying the Unit Down	34

Section 4: Maintenance

Emissions Information	35
Daily Walk-Around Inspection	35
General Maintenance	35
Preparing for Service	35
Cleaning the Unit	35
Inspecting the Unit	35
Basic Maintenance Schedule	36
Resetting the Maintenance Alarms (If Equipped)	38
Manual Winch: Use, Operation, and Maintenance	38
Prior to Use	38
Operation	38
Maintenance	38
Electric Winch: Use, Operation, and Maintenance	38
Winch Mechanical Brake	39
Jack Maintenance	39
Trailer Wheel Bearings	39

Section 5: Troubleshooting

General Troubleshooting	41
Troubleshooting the Lights	42

Section 6: Wiring Diagrams

Mast Junction Box Wiring and Light Connections	43
AC Wiring Diagram	44
DC Wiring Diagram	45
DC Wiring - Electric Winch Option	46
Trailer Lights Wiring	47

Section 7: Service Log

Section 1: Introduction and Safety

Introduction

Thank you for purchasing a Generac Mobile Products LLC product. This unit has been designed to provide high performance, efficient operation, and years of use when maintained properly.

The information in this manual is accurate based on products produced at the time of publication. The manufacturer reserves the right to make technical updates, corrections, and product revisions at any time without notice.

Read This Manual Thoroughly



Consult Manual. Read and understand manual completely before using product. Failure to completely understand manual and product could result in death or serious injury. (000100a)

If any section of the manual is not understood, contact your nearest Generac Mobile Products Authorized Service Dealer, or contact Generac Mobile Products LLC at 1-800-926-9768, or Generac Mobile Products Technical Service at 1-800-926-9768 or www.generacmobileproducts.com with any questions or concerns.

The owner is responsible for proper maintenance and safe use of the equipment. Comply with regulations the Occupational Safety and Health Administration (OSHA) has established, or with equivalent standards. Also, verify that the unit is applied, used, and maintained in accordance with the manufacturer's instructions and recommendations. Do nothing that might alter safe application/usage and render the unit in noncompliance with the aforementioned codes, standards, laws, and regulations.

Save these instructions for future reference. This manual contains important instructions for the unit that should be followed during setup, operation and maintenance of the unit and battery. ALWAYS supply this manual to any individual that will use this machine.

How to Obtain Service

When the unit requires servicing or repairs, contact a GMP ASD for assistance. Service technicians are factory-trained and are capable of handling all service needs. For assistance locating a dealer, go to www.generacmobileproducts.com/parts-service/find-service. When contacting a Generac Mobile Products Authorized Service Dealer about parts and service, always supply the complete model number and serial number of the unit as given on its data decal located on the unit. Record the model number and serial numbers in the spaces provided on the inside front cover of this manual.

Safety Rules

The manufacturer cannot anticipate every possible circumstance that might involve a hazard. The warnings in this manual, and on tags and decals affixed to the unit are, therefore, not all inclusive. If using a procedure, work method or operating technique that the manufacturer does not specifically recommend, verify that it is safe for others. Also make sure the procedure, work method or operating technique utilized does not render the equipment unsafe.

Throughout this publication, and on tags and decals affixed to the unit, DANGER, WARNING, CAUTION and NOTE blocks are used to alert personnel to special instructions about a particular operation that may be hazardous if performed incorrectly or carelessly. Observe them carefully. Their definitions are as follows:



Indicates a hazardous situation which, if not avoided, will result in death or serious injury.

(000001)



Indicates a hazardous situation which, if not avoided, could result in death or serious injury.

(000002)



Indicates a hazardous situation which, if not avoided, could result in minor or moderate injury.

(000003)

NOTE: Notes contain additional information important to a procedure and will be found within the regular text of this manual.

These safety alerts cannot eliminate the hazards that they indicate. Common sense and strict compliance with the special instructions while performing the action or service are essential to preventing accidents.

General Hazards



⚠ DANGER

Asphyxiation. Running engines produce carbon monoxide, a colorless, odorless, poisonous gas. Carbon monoxide, if not avoided, will result in death or serious injury. (000103)



⚠ WARNING

Hearing Loss. Hearing protection is recommended when using this machine. Failure to wear hearing protection could result in permanent hearing loss. (000107)



⚠ WARNING

Moving Parts. Keep clothing, hair, and appendages away from moving parts. Failure to do so could result in death or serious injury. (000111)



⚠ WARNING

Hot Surfaces. When operating machine, do not touch hot surfaces. Keep machine away from combustibles during use. Hot surfaces could result in severe burns or fire. (000108)

⚠ WARNING

Risk of injury. Do not operate or service this machine if not fully alert. Fatigue can impair the ability to service this equipment and could result in death or serious injury. (000215)



⚠ WARNING

Risk of burns. Allow engine to cool before draining oil or coolant. Failure to do so could result in death or serious injury. (000139)

Explosion and Fire Hazards



⚠ DANGER

Explosion and Fire. Fuel and vapors are extremely flammable and explosive. Add fuel in a well ventilated area. Keep fire and spark away. Failure to do so will result in death or serious injury. (000105)



⚠ WARNING

Risk of Fire. Unit must be positioned in a manner that prevents combustible material accumulation underneath. Failure to do so could result in death or serious injury. (000147)



⚠ WARNING

Risk of Fire. Hot surfaces could ignite combustibles, resulting in fire. Fire could result in death or serious injury. (000110)

Trailer Hazards

⚠ WARNING

Personal injury. Trailer must be securely coupled to the hitch with the chains correctly attached. Uncoupled or unchained towing could result in death or serious injury. (000233a)

⚠ WARNING

Personal injury. Do not operate unit during transport. Doing so could result in death, serious injury, or property damage. (000231a)

⚠ WARNING

Crushing hazard. Verify unit is properly secured and on level ground. An unsecured unit can suddenly roll or move, causing death or serious injury. (000234a)

⚠ WARNING

Property or Equipment Damage. Tighten wheel lug nuts after first 50 miles to factory specifications. Failure to do so could result in death, serious injury, property or equipment damage. (000235)

Electrical Hazards



⚠ DANGER

Electrocution. In the event of electrical accident, immediately shut power OFF. Use non-conductive implements to free victim from live conductor. Apply first aid and get medical help. Failure to do so will result in death or serious injury. (000145)



⚠ DANGER

Electrocution. Water contact with a power source, if not avoided, will result in death or serious injury.

(000104)



⚠ DANGER

Electrocution. Contact with bare wires, terminals, and connections while generator is running will result in death or serious injury.

(000144)



⚠ DANGER

Electrocution. Verify electrical system is properly grounded before applying power. Failure to do so will result in death or serious injury.

(000152)



⚠ DANGER

Electrocution. Do not wear jewelry while working on this equipment. Doing so will result in death or serious injury.

(000188)



⚠ DANGER

Electrocution. DO NOT use the unit if electrical cord is cut or worn through. Doing so will result in death or serious injury.

(000263a)

Battery Hazards



⚠ DANGER

Electrocution. Do not wear jewelry while working on this equipment. Doing so will result in death or serious injury.

(000188)



⚠ WARNING

Explosion. Batteries emit explosive gases while charging. Keep fire and spark away. Wear protective gear when working with batteries. Failure to do so could result in death or serious injury.

(000137a)



⚠ WARNING

Explosion. Do not dispose of batteries in a fire. Batteries are explosive. Electrolyte solution can cause burns and blindness. If electrolyte contacts skin or eyes, flush with water and seek immediate medical attention.

(000162)



⚠ WARNING

Risk of burn. Do not open or mutilate batteries. Batteries contain electrolyte solution which can cause burns and blindness. If electrolyte contacts skin or eyes, flush with water and seek immediate medical attention.

(000163a)

⚠ WARNING

Environmental Hazard. Always recycle batteries at an official recycling center in accordance with all local laws and regulations. Failure to do so could result in environmental damage, death or serious injury.

(000228)

Always recycle batteries in accordance with local laws and regulations. Contact your local solid waste collection site or recycling facility to obtain information on local recycling processes. For more information on battery recycling, visit the Battery Council International website at: <http://batteryCouncil.org>

Fuel Hazards



⚠ DANGER

Explosion and fire. Fuel and vapors are extremely flammable and explosive. No leakage of fuel is permitted. Keep fire and spark away. Failure to do so will result in death or serious injury. (000192)



⚠ DANGER

Risk of fire. Allow fuel spills to completely dry before starting engine. Failure to do so will result in death or serious injury. (000174)

- **DO NOT** fill fuel tank near an open flame, while smoking, or while engine is running. **DO NOT** fill tank in an enclosed area with poor ventilation.
- **DO NOT** operate with the fuel tank cap loose or missing.

Engine Safety

Internal combustion engines present special hazards during operation and fueling. Failure to follow the safety guidelines described below could result in severe injury or death. Read and follow all safety alerts described in the engine operator's manual. A copy of this manual was supplied with the unit when it was shipped from the factory.

- **DO NOT** run engine indoors or in an area with poor ventilation. Make sure engine exhaust cannot seep into closed rooms or ventilation equipment.
- **DO NOT** clean air filter with gasoline or other types of low flash point solvents.
- **DO NOT** operate the unit without a functional exhaust system.
- Shut the engine down if any of the following conditions exist during operation:
 - Noticeable change in engine speed.
 - Loss of electrical output.
 - Equipment connected to the unit overheats.
 - Sparking occurs.
 - Engine misfires or there is excessive engine/generator vibration.
 - Protective covers are loose or missing.
 - Ambient air temperature is above 120°F (49°C).

Operating Safety

Positioning the Unit



⚠ DANGER

High Voltage. Verify area above unit is clear of overhead wires and obstructions. Contact with high-voltage power lines will result in death or serious injury. (000260a)



⚠ WARNING

Burn hazard. Never operate lights with a damaged or missing lens cover. Lamps are hot and pressurized while in use. Unprotected lamps can shatter, causing severe injury. (000277)

- The area immediately surrounding the unit should be dry, clean, and free of debris.
- Position and operate the unit on a firm, level surface.
- If the unit is equipped with a frame grounding stud, follow the National Electrical Code (NEC), state, and local regulations when connecting.

Starting the Unit



⚠ DANGER

Electrocution. **DO NOT** use the unit if electrical cord is cut or worn through. Doing so will result in death or serious injury. (000263a)

⚠ WARNING

Equipment damage. Do not attempt to start or operate a unit in need of repair or scheduled maintenance. Doing so could result in serious injury, death, or equipment failure or damage. (000291)

Raising and Lowering the Mast



⚠️ WARNING

Electrocution. Do not set up or operate this unit if severe weather is expected. Lightning strikes can kill or cause severe injury even if you are not touching the unit. (000296)



> 60 mph

⚠️ WARNING

Do not set up the unit if high winds are expected. High winds can cause the unit to tip or fall, causing severe injury or machine damage. (000297)

⚠️ WARNING

Personal injury or equipment damage. Do not raise or lower the mast while the unit is operating. Doing so can break the lenses and cause the lamps to shatter. (000279)

⚠️ WARNING

Personal Injury. Stop immediately if the mast hangs up or the winch cable develops slack. Excess slack could cause the mast to collapse, resulting in personal injury or equipment damage. (000265)

⚠️ WARNING

Tipping hazard. Extend the outriggers and level the unit before raising the mast. Keep the outriggers extended while the mast is up. Failure to do so could cause the unit to tip and fall and could result in death or serious injury. (000266)



⚠️ WARNING

Burn hazard. Lamps become extremely hot while in use. Allow 10–15 minutes for cooling before handling or lowering mast. Touching a hot lens or fixture can cause severe burns. (000278)

- Keep area around the unit clear of people while raising and lowering the mast.
- **ALWAYS** lower the mast when not in use.
- The tower extends up to 23 ft (7 m). Verify area above trailer is open and clear of overhead wires and obstructions.
- If for any reason any part of mast hangs up or winch cable develops slack while raising or lowering tower, STOP immediately! Contact a Generac Mobile Products Authorized Service Dealer.
- **NEVER** remove safety pin or pull mast locking pin while tower is up.

Service Safety

This unit uses high voltage circuits capable of causing serious injury or death. Only a qualified and licensed electrician should troubleshoot or repair problems occurring in this equipment.

- Before servicing the unit, verify the Control Power switch and circuit breakers are in the OFF (O) position, and the negative (-) terminal on the battery is disconnected. **DO NOT** perform even routine service (oil/filter changes, cleaning, etc.) unless all electrical components are shut down.
- **ALWAYS** use extreme caution when servicing this unit in damp conditions. Do not service the unit if your skin or clothing is wet. Do not allow water to collect around the base of the unit.
- **DO NOT** wash the unit with high pressure hoses, power washers, or steam cleaners. Water may collect in the unit, causing damage to electrical parts.
- Replace all missing and hard to read decals. Decals provide important operating instructions and warn of dangers and hazards.
- Wear heavy leather gloves when handling winch cables. Never let cables slip through bare hands.
- Only use mild soap and water to clean the lens covers. Other chemicals may damage the lens covers.

Towing Safety

Towing a trailer requires care. Both the trailer and vehicle must be in good condition and securely fastened to each other to reduce the possibility of an accident. Some states require that large trailers be registered and licensed. Contact your local Department of Transportation office to check on license requirements for your particular unit.

Hitch and Coupling

- Verify the hitch and coupling on the towing vehicle are rated equal to, or greater than, the trailer's Gross Vehicle Weight Rating (GVWR).
- Verify the trailer hitch and the coupling are compatible. Make sure the coupling is securely fastened to the vehicle.
- **DO NOT** tow trailer using defective parts. Inspect the hitch and coupling for wear or damage.
- Connect safety chains in a crossing pattern under the tongue.
- Before towing the trailer, verify that the weight of the trailer is equal across all tires. On trailers with adjustable height hitches, adjust the angle of the trailer tongue to keep the trailer as level as possible.

Running Lights

Verify directional and brake lights on the trailer are connected and working properly

Wheels and Tires

- Check trailer tires for wear and proper inflation.
- Verify wheel lug nuts are present and tightened to the specified torque.

Safe Towing Techniques

- Practice turning, stopping and backing up in an area away from heavy traffic prior to transporting the unit.
- Maximum recommended speed for highway towing is 45 mph (72 km/h). Recommended off-road towing speed is 10 mph (16 km/h) or less, depending on terrain.
- When towing, maintain extra space between vehicles and avoid soft shoulders, curbs and sudden lane changes.

Reporting Trailer Safety Defects

If you believe your trailer has a defect which could cause a crash or could cause injury or death, you should immediately inform the National Highway Traffic Safety Administration (NHTSA) in addition to notifying Generac Mobile Products LLC.

If NHTSA receives similar complaints, it may open an investigation; and if it finds that a safety defect exists in a group of vehicles, it may order a recall and remedy campaign. However, NHTSA cannot become involved in an individual problem between you, your dealer, or Generac Mobile Products LLC.

To contact NHTSA, you may either call the Auto Safety Hotline toll-free at 1-888-327-4236 (TTY:1-800-424-9153), go to <http://www.safercar.gov>; or write to:

Administrator
NHTSA
1200 New Jersey Avenue S.E.
Washington, DC 20590

You can also obtain other information about motor vehicle safety from <http://www.safercar.gov>.

Safety and Operating Decals

See [Figure 1-1](#) through [Figure 1-3](#). This unit features numerous safety and operating decals. These decals provide important operating instructions and warn of dangers and hazards. The following diagrams illustrate decal locations and descriptions.

Replace any missing or hard-to-read decals and use care when washing or cleaning the unit. Decal part numbers can be found in the parts manual at www.generacmobileproducts.com.

ID	Description	ID	Description
1	Setup and Take-Down Instructions (Electric)	15	Control Panel Label (not shown)
2	Setup and Take-Down Instructions (Manual)	16	Neutral Bonded to Frame
3	Danger—Overhead Power Lines	17	Not A Step
4	Warning—Electrical Storms and High Wind	18	Warning—High Temperature: Do Not Remove Guard
5	Owner's Manual Location	19	Mast Junction Box Wiring (inside)
6	Electric Shock Hazard	20	Warning—Do Not Retract Outriggers With Tower Up
7	Warning—Pressurized Liquid	21	Stowed Position
8	Warning—Hot Surface	22	Lifting Point
9	Warning—Entanglement Hazard	23	Forklift and Tie-Down Point
10	Warning—Cutting Hazard	24	Engine Operation
11	Disconnect Battery Before Servicing	25	Ultra Low Sulfur Diesel Fuel Only
12	Danger—Carbon Monoxide	26	Danger—Fuel and Fueling Hazards
13	Electrical Ground Connection	27	Tie-Down Point
14	Danger—Ultraviolet Radiation / Winch Operation	28	Towing Instructions

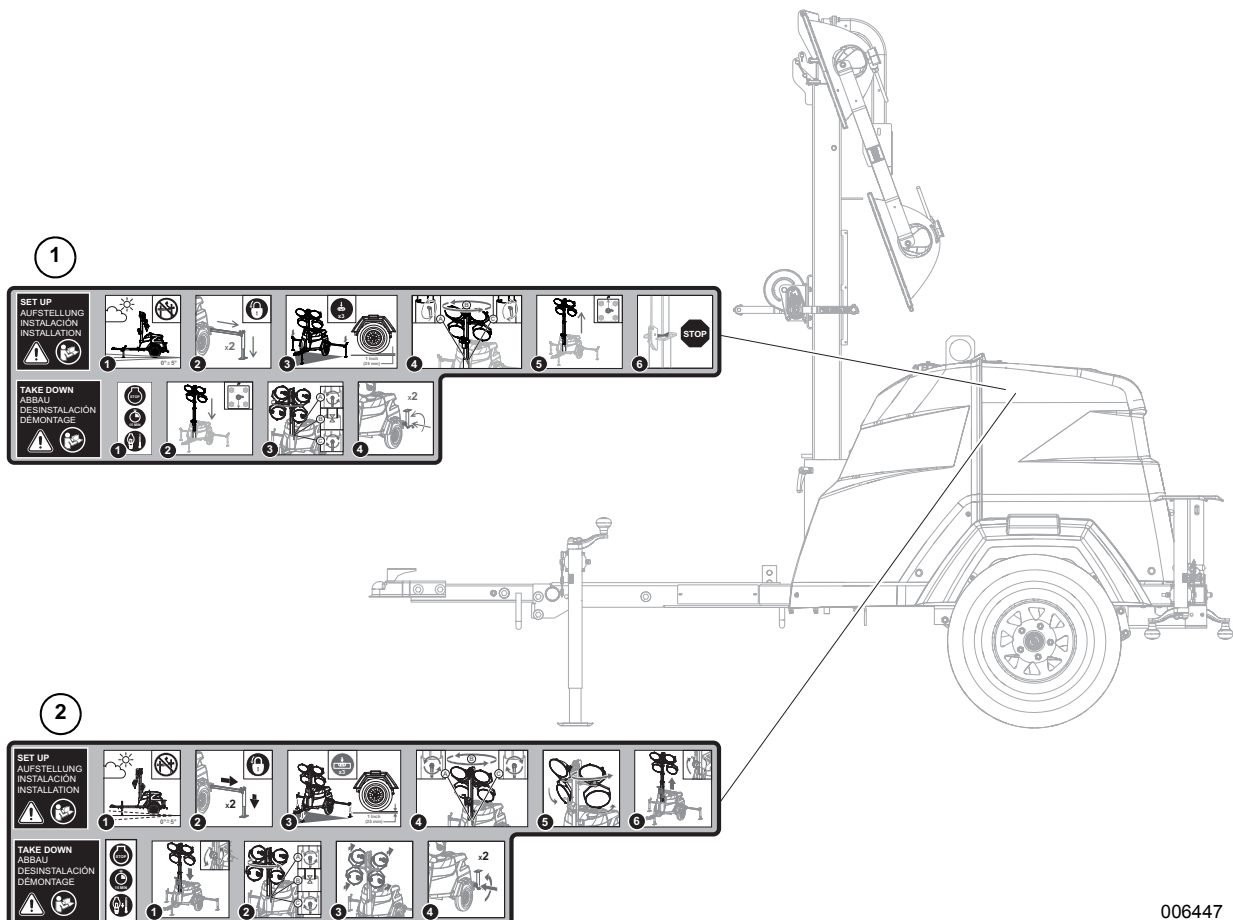

Figure 1-1. Decal Locations (1 of 3)

006447

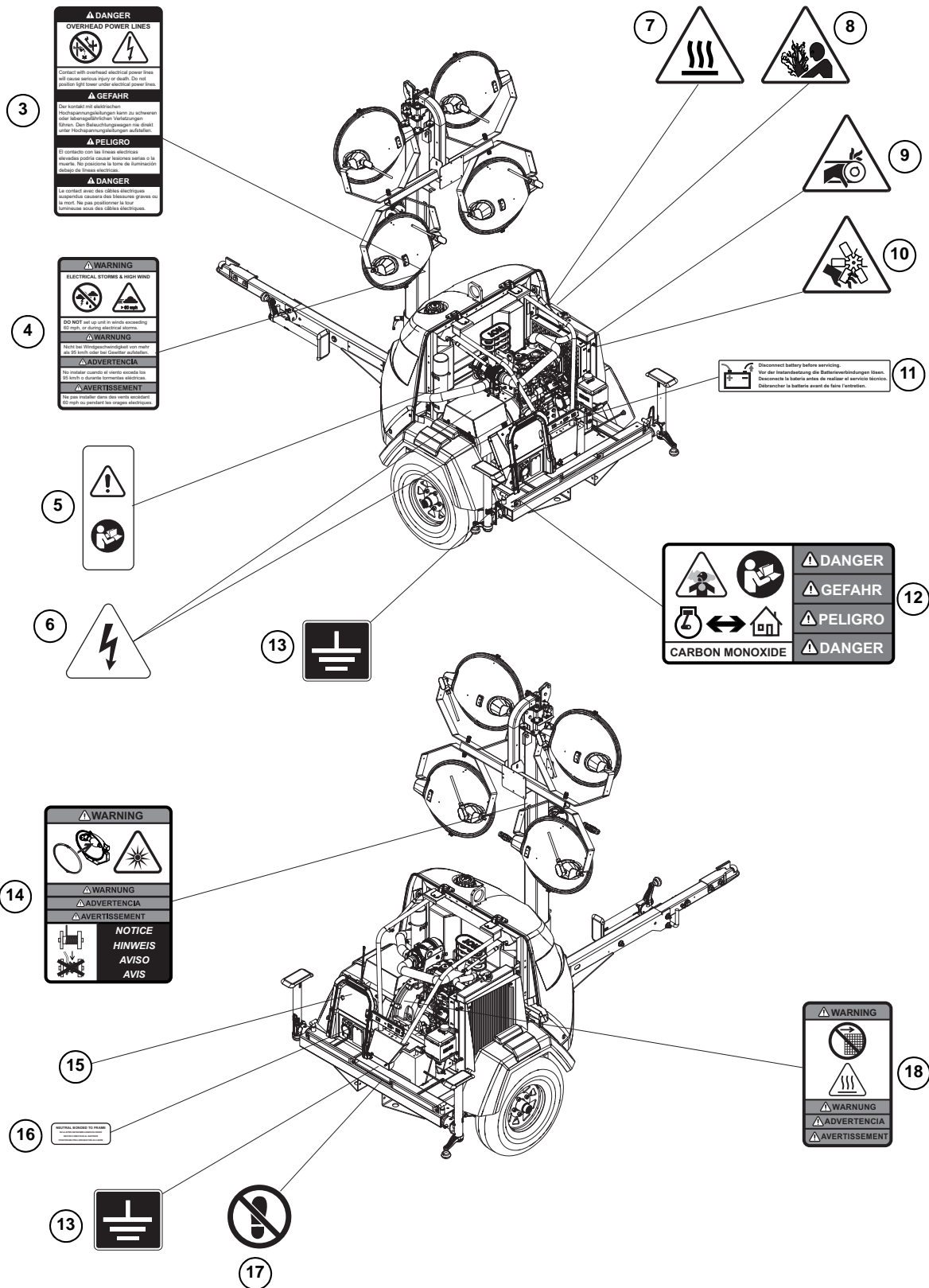

Figure 1-2. Decal Locations (2 of 3)

006448

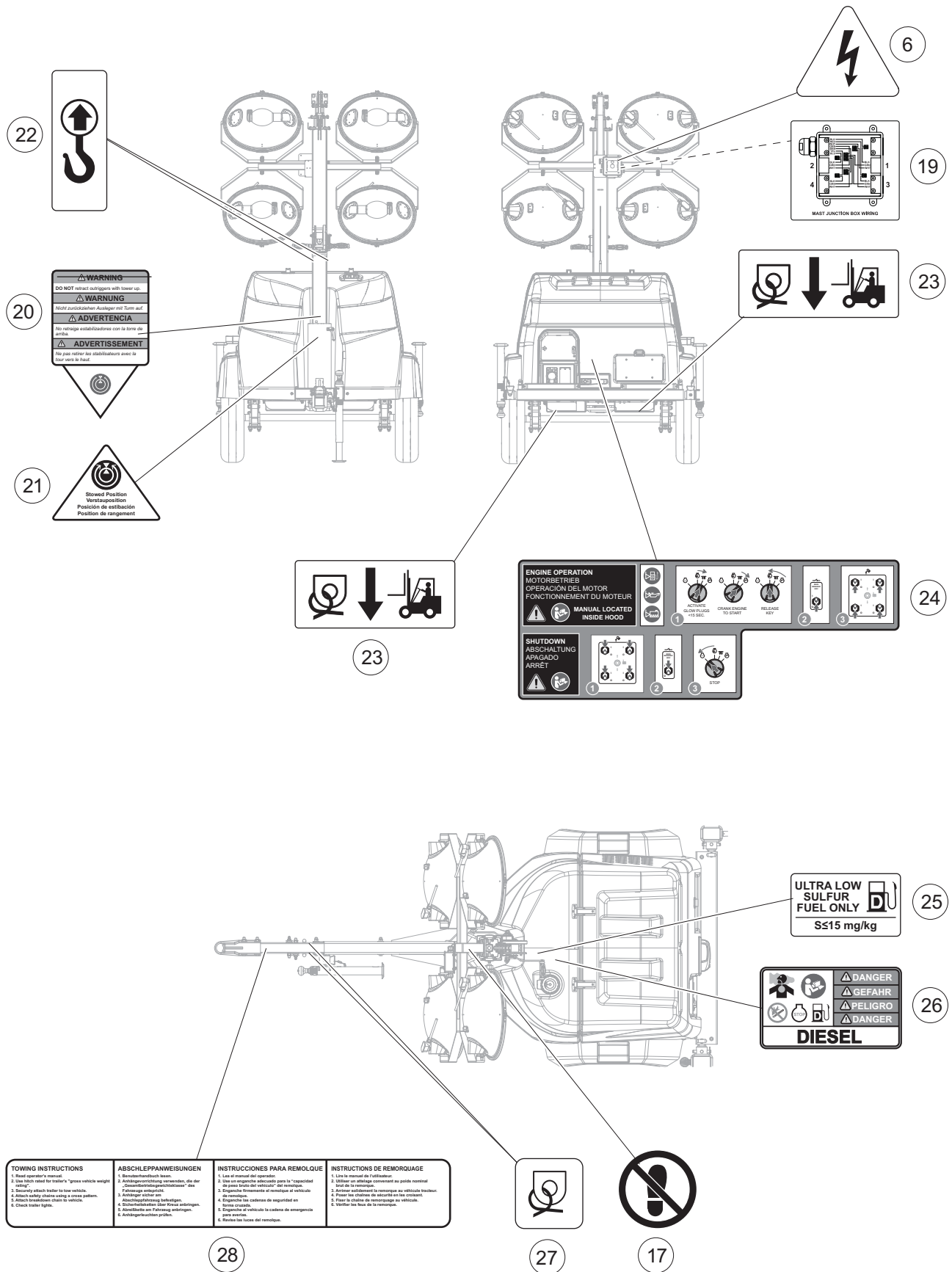

Figure 1-3. Decal Locations (3 of 3)

006449

This page intentionally left blank.

Section 2: General Information

Specifications

DESCRIPTION	UNITS	MLT6SC
Engine		
EPA Tier	—	Tier 4 Final
Fuel Consumption—100% Prime	gph (Lph)	0.74 (2.80)
Battery Type—Group Number	—	24
Battery Voltage	quantity per unit	12 (1)
Battery Rating	cold-cranking amp-hours	440
Generator		
Output - Standby	kW (kVA)	6.0 (6.0)
Output Voltage	volts	120/240, single phase
Output Amperes 120V (240V)	amperes	20 (25)
Frequency Hz	Hertz	60
Weights		
Dry Weight	lbs (kg)	1316 (597)
Operating Weight	lbs (kg)	1586 (719)
Capacities		
Fuel Tank Volume	gal (L)	40.75 (154.26)
Usable Fuel Volume	gal (L)	39.9 (151.04)
Coolant (including engine)	qt (L)	5.0 (4.7)
Oil (including filter)	qt (L)	4.6 (4.4)
Maximum Run Time	hours	59
AC Distribution		
Circuit Breaker Size	amperes	30
Trailer		
Hitch—Standard	—	2 in. ball
Maximum Tire Pressure	psi (kPA)	50 (345)
<i>Specifications are subject to change without notice.</i>		

Unit Serial Number Locations

Refer to the illustration to locate the unit ID tag and Vehicle Identification Number (VIN) tag on the unit. Important information, such as the unit serial number, model number, VIN and tire loading information are found on these tags. Record the information from these tags so it is available if the tags are lost or damaged. When ordering parts or requesting assistance, you may be asked to provide this information.

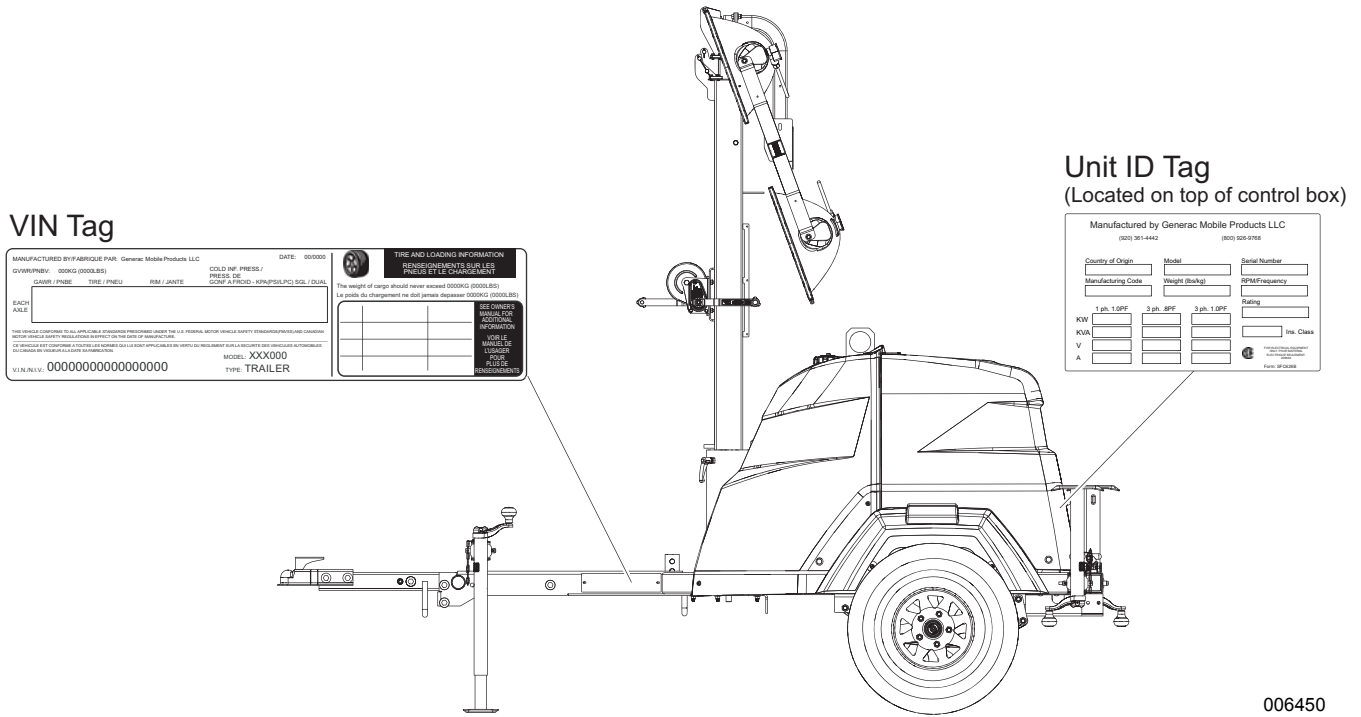

Figure 2-1. Serial Number Locations

006450

Trailer Tongue Storage and Tow Positions

The trailer tongue is designed to fold upright for shipping and storage.

IMPORTANT NOTE: Do not attempt to tow the unit with trailer tongue in the storage position.

Place Trailer Tongue in Tow Position

1. Verify unit is on a level surface and wheels are blocked.

NOTE: See [Figure 2-2](#). Unit ships from factory with jack in the storage location (A).

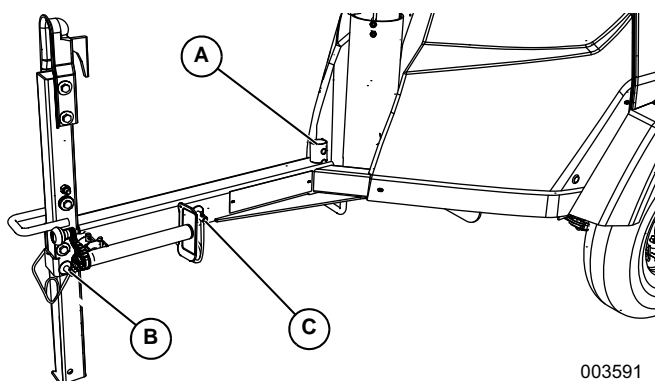

Figure 2-2. Jack and Pin Locations

2. Remove clevis securing jack parallel to ground.
3. Remove jack from tongue weldment. Hold jack vertically and extend until weldment on jack is aligned with tongue weldment.
4. See [Figure 2-3](#). Install jack and secure with clevis (D).

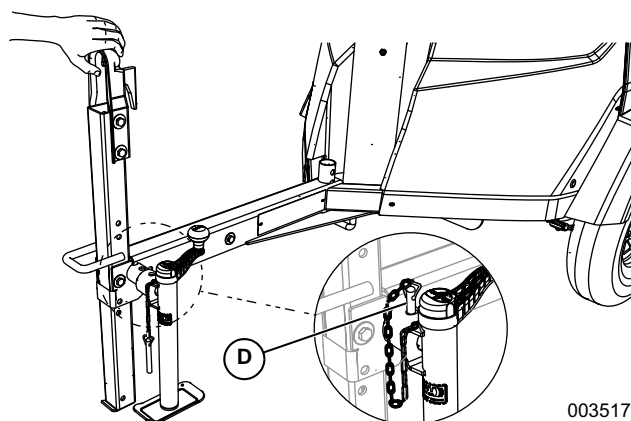

Figure 2-3. Jack Installed

5. See [Figure 2-2](#). Remove pins (B) and (C).



CAUTION

Pinching and crushing hazard. To avoid possible injury, keep fingers away from pivot point when folding or unfolding trailer tongue.

(000313)

6. See [Figure 2-4](#). Using both hands, slowly lower trailer tongue into tow position.

NOTE: Varying levels of effort may be required depending on terrain.

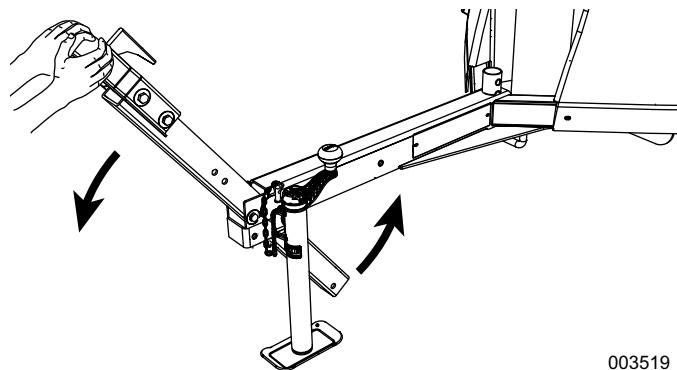

003519

Figure 2-4. Lower Trailer Tongue into Tow Position

7. See [Figure 2-5](#). Install pins as shown to secure trailer tongue in tow position.

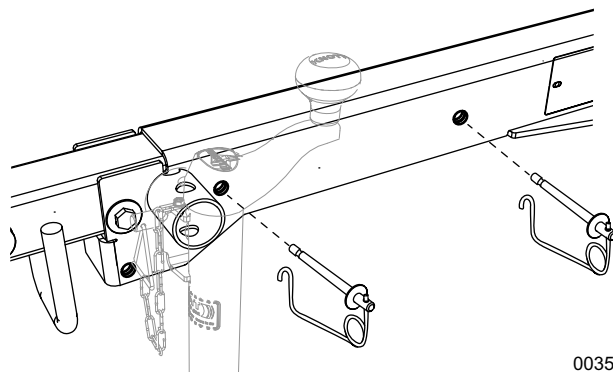

003592

Figure 2-5. Install and Secure Pins

Place Trailer Tongue in Storage Position

1. Verify unit is on a level surface and wheels are blocked.
2. See **Figure 2-6**. Extend jack (A) enough to allow minimum effort to pivot trailer tongue into storage position.

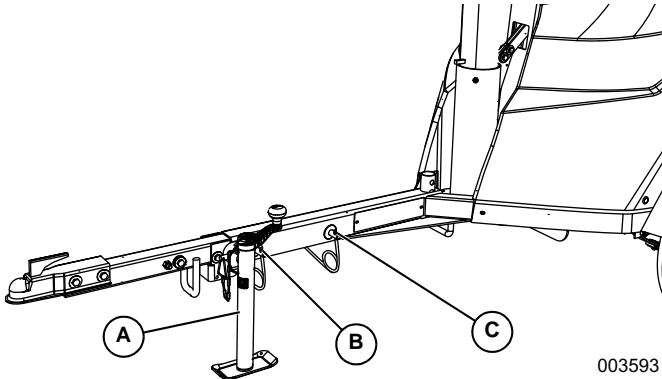

Figure 2-6. Extend Jack and Remove Pins

3. Remove pins (B) and (C) from trailer tongue.



CAUTION

Pinching and crushing hazard. To avoid possible injury, keep fingers away from pivot point when folding or unfolding trailer tongue.

(000313)

4. See **Figure 2-7**. Pivot trailer tongue into storage position.

NOTE: Varying levels of effort may be required depending on terrain.

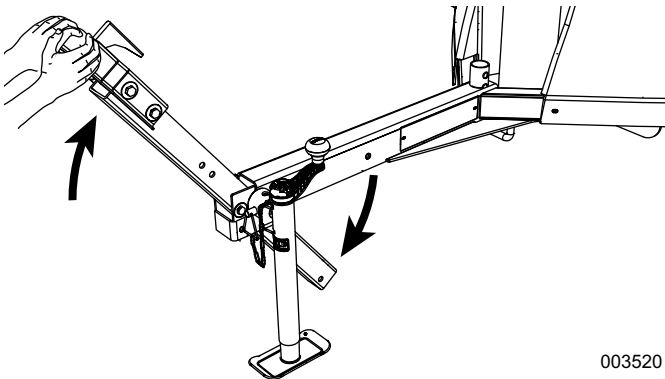

Figure 2-7. Pivot Trailer Tongue Into Storage Position

5. See **Figure 2-8**. Install pins (B) and (C) at locations shown to secure trailer tongue in storage position.

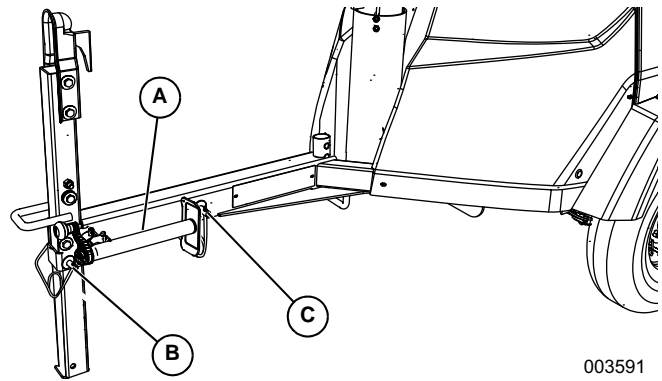
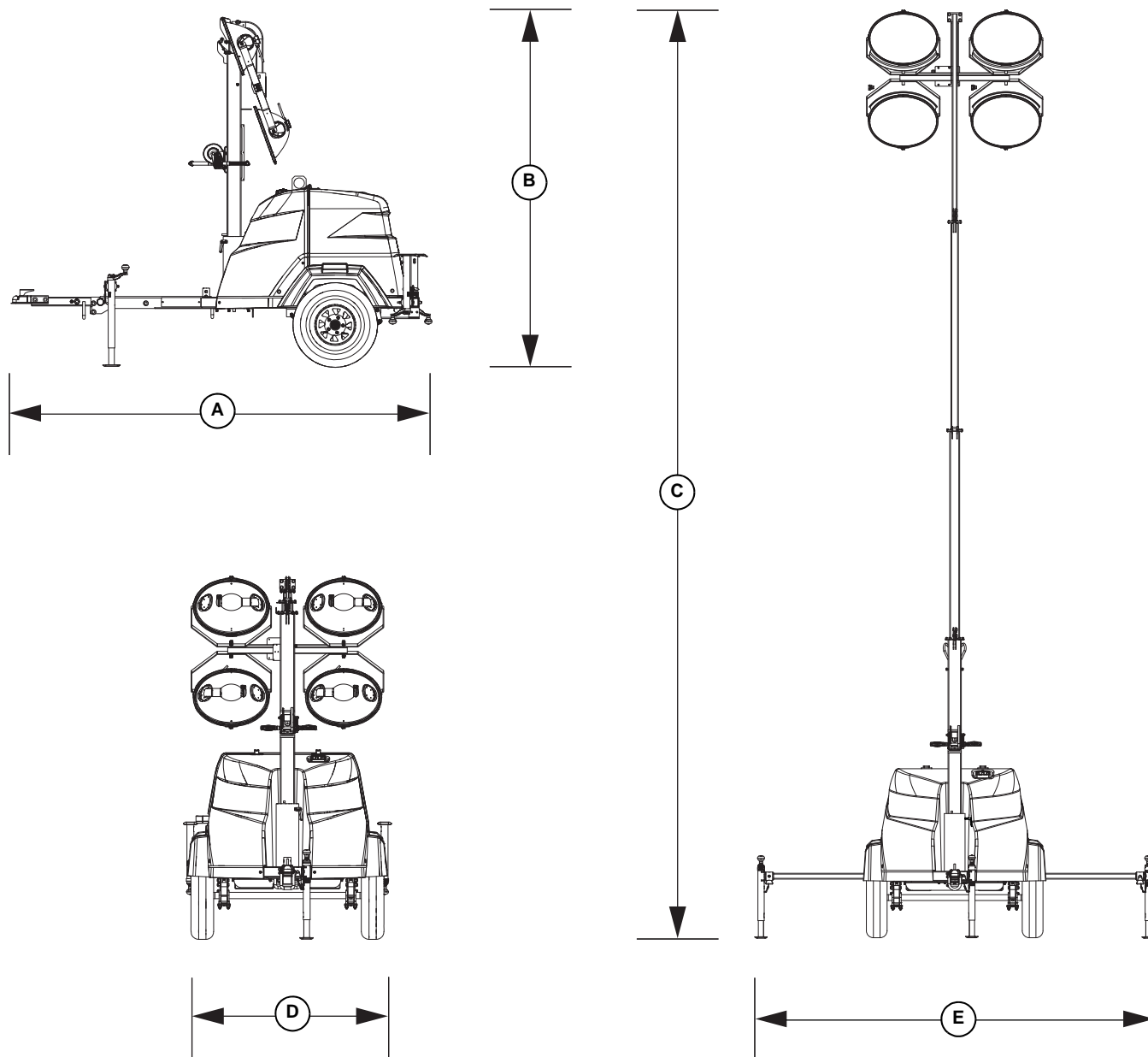

Figure 2-8. Install Pins and Rotate Jack

6. Remove clevis and remove jack (A) from tongue weldment.
7. Completely retract jack.
8. Rotate jack 90° counterclockwise, place jack on tongue weldment, and install clevis to secure jack parallel to ground.

Unit Dimensions



006451

Figure 2-9. Unit Dimensions

	A	B	C	D	E
MLT6SC	118 in. (3 m)	101 in. (2.6 m)	23 ft. (7 m)	57 in. (1.5 m)	120.5 in. (3.1 m)

Specifications are subject to change without notice.

Component Locations

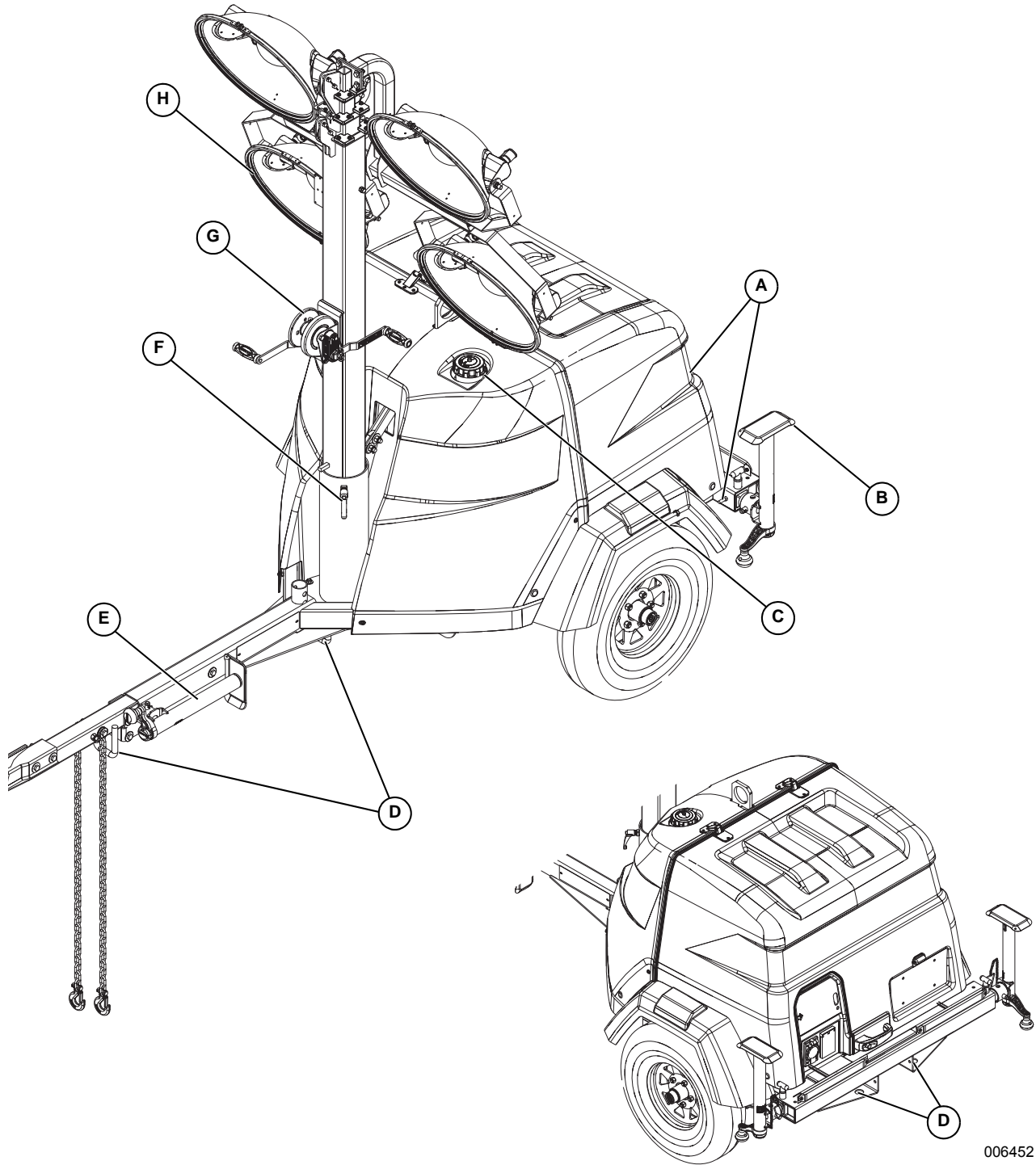

006452

Figure 2-10. Component Locations—Front and Left Side

- | | |
|--|---|
| <p>A. Grounding studs:
Interior: On enclosure floor behind controller
Exterior: On bumper</p> <p>B. Outriggers and jacks (2)</p> <p>C. Fuel fill</p> <p>D. Tie-down location</p> | <p>E. Tongue jack</p> <p>F. Mast rotation knob</p> <p>G. Winch</p> <p>H. Lights (4)</p> |
|--|---|

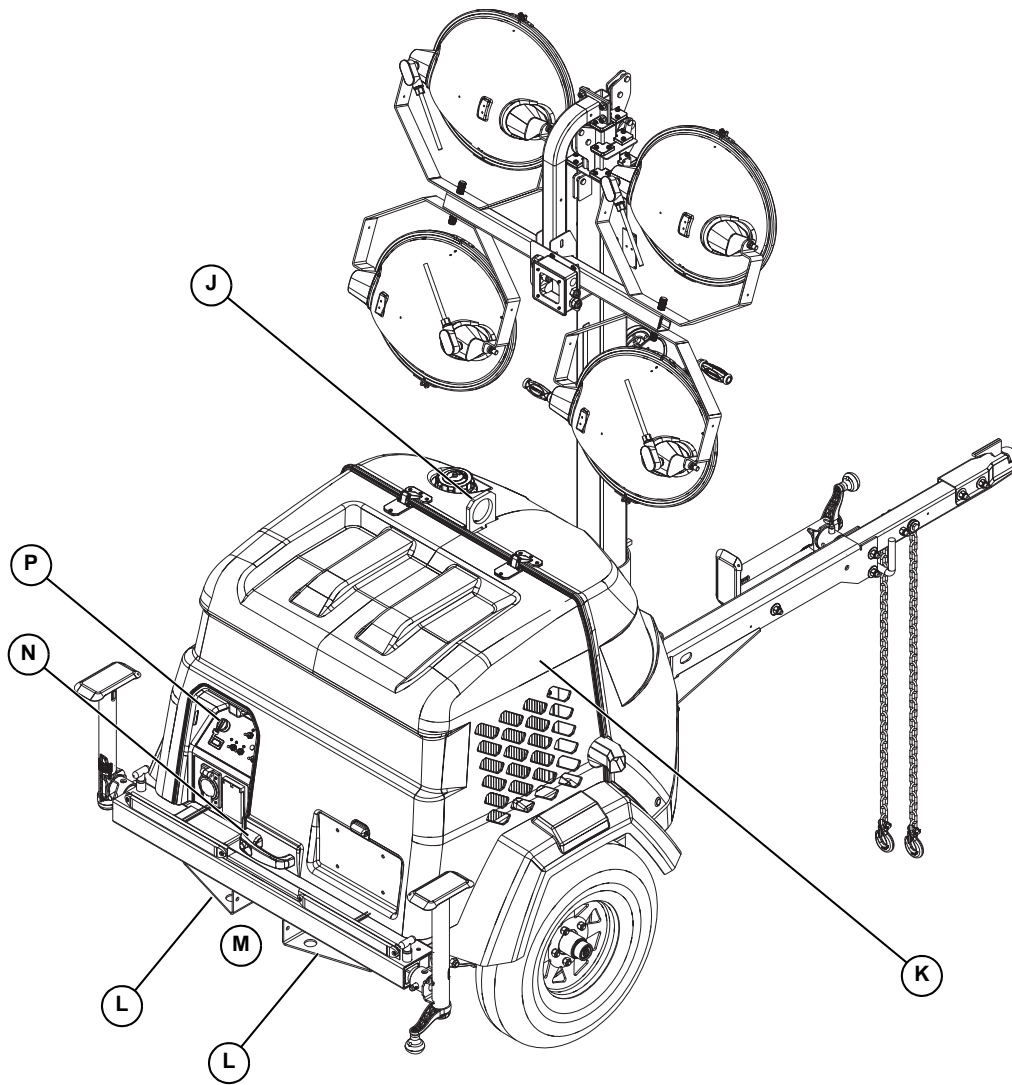

006453

Figure 2-11. Component Locations—Rear and Right Side

- | | |
|---------------------------------------|---|
| J. Central lift point | M. Tandem tow mount (optional—not shown) |
| K. Engine/radiator access hood | N. Hood latch |
| L. Forklift pocket | P. Key start controller
or Power Zone-DLA controller (optional—not shown) |

Control Panel

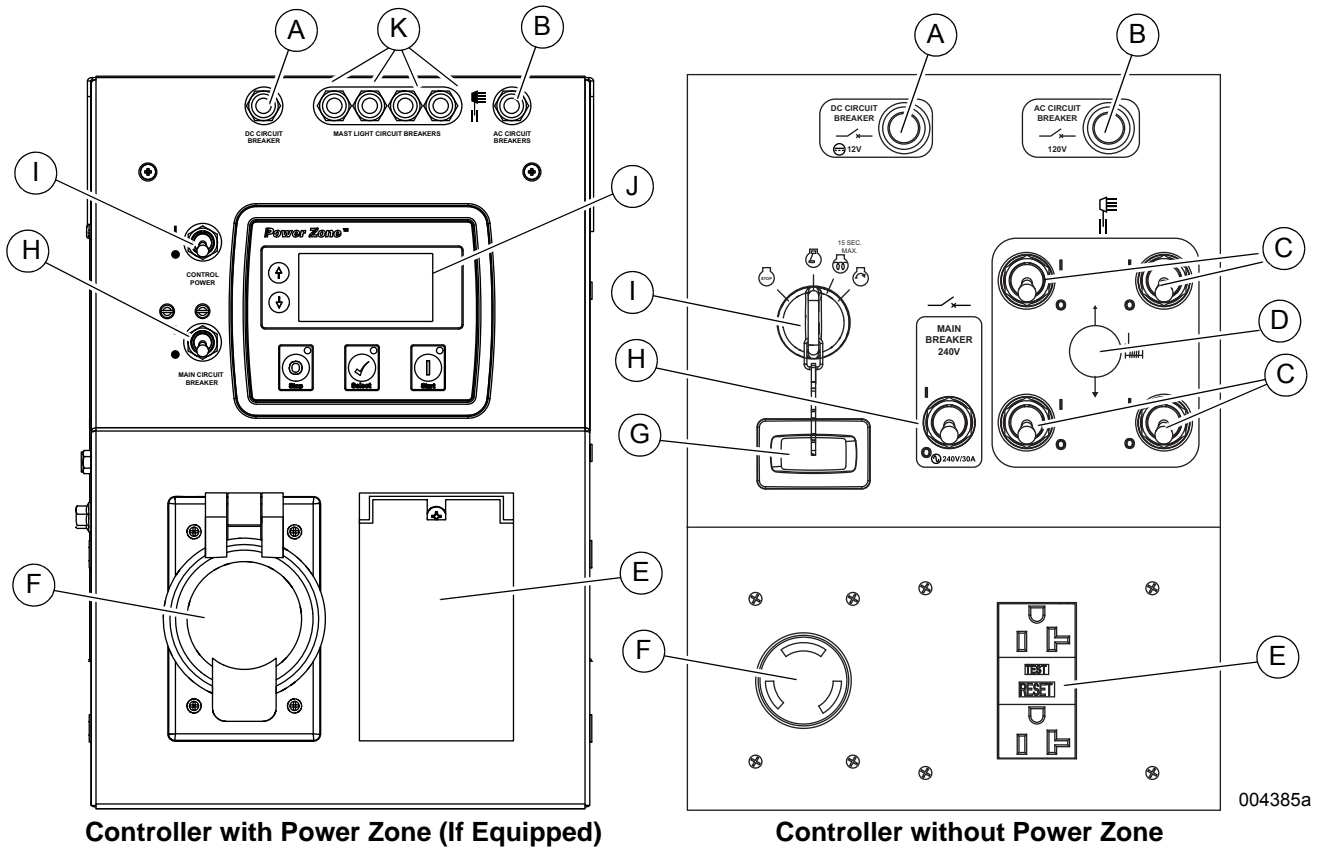

Figure 2-4. Control Panel

Control Panel Features and Functions

(A) DC circuit breaker

Resets the DC electrical circuit that powers the control panel and engine components.

(B) AC circuit breaker

Resets the AC electrical circuit that powers the control panel.

(C) Mast light toggle switch/circuit breakers (4)

Power switches with internal breakers dedicated to individual lights

(D) Mast switch (if equipped)

Raises and lowers the mast on units equipped with an electric winch.

(E) 120V/20A GFCI outlet

Customer convenience outlet for use in connecting auxiliary equipment such as fans, pumps, drills. Includes a Ground Fault Circuit Interrupter (GFCI) test and reset button.

(F) 240VAC/30A twist-lock outlet

Customer convenience outlet for use in connecting auxiliary equipment such as fans, pumps, drills.

(G) Engine hour meter

Displays number of hours the engine has run.

(H) Main circuit breaker

240V/30A breaker which disconnects power from the lights and control panel.

(I) Control power switch

Turns the engine ON and OFF.

(J) Power Zone controller

Monitors the unit and indicates operational status and fault conditions.

(K) Mast light circuit breakers (4)

Power switches with internal breakers dedicated to individual lights

Power Zone–DLA (If Equipped)

The Power Zone–DLA is an AUTO start controller that monitors the unit and indicates operational status and fault conditions. The controller can be programmed to automatically start or stop based on time schedule, fault condition, or load demand.

The controller constantly monitors vital generator and engine functions for a number of preprogrammed alarm and fault conditions. When a fault condition occurs, the

engine will be shut down automatically and the LCD window will show the fault that caused the shutdown. To resume operation, the fault condition must be corrected.

This controller also records a history of unit performance, which may be viewed at any time and will not be lost when the controller is powered down.

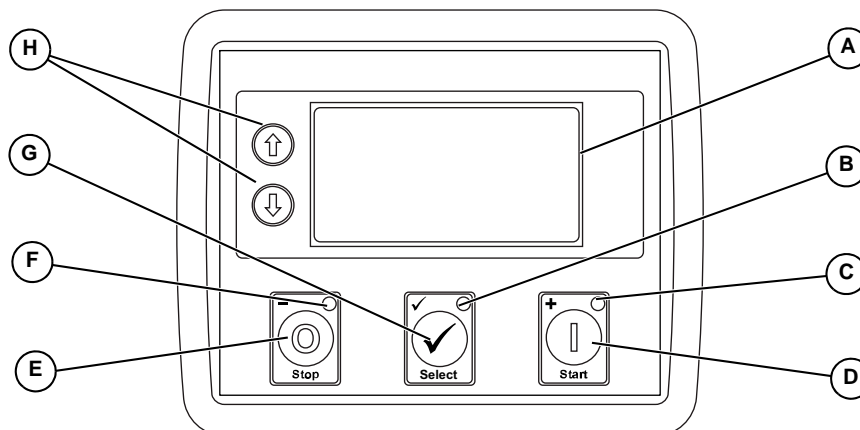

Figure 2-5. Power Zone–DLA Layout

002353

Controller Features and Functions

(A) The Liquid Crystal Display (LCD) Window

This window displays the various operating screens. By viewing these screens, the operator can monitor both the engine and generator status while the unit is running.

(B) Select LED

This LED illuminates when the unit is running in AUTO mode.

(C) Start LED

This LED illuminates when the unit is running in MANUAL mode.

(D) Start Button

This button starts the engine if there are no shutdown errors and the engine is in “ready to start” status.

(E) Stop Button

This button shuts down the unit and puts the controller into STOP mode, whether in MANUAL mode or AUTO mode.

NOTE: To prevent damage to the generator and connected equipment, remove all loads from the generator by opening all circuit breakers (turn OFF [O]) before pressing the STOP button.

(F) Stop LED

This LED illuminates when the unit is in STOP mode and flashes when an Electrical Trip and Shutdown Fault has occurred.

(G) Select Button

This button confirms entries chosen in the various edit menus and screens.

(H) Menu Navigation

These buttons (↑, ↓) are used to navigate through the various operator screens. They are also used to raise and lower the mast on units equipped with an electric winch.

Operator Screens

See [Figure 2-6](#). The operator screens display the most relevant and critical information an operator will need to properly configure and use the unit. From these six screens, the operator can access information necessary to operate the unit under normal conditions.

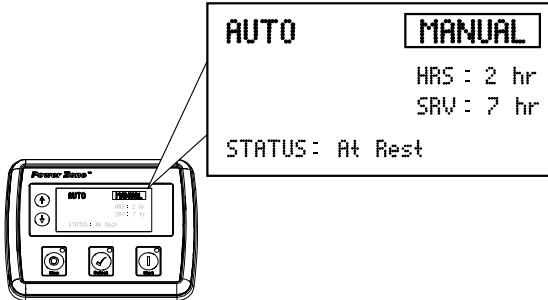

002354

Figure 2-6. Operator Screens Location

Home Screen

See [Figure 2-7](#). The Home screen is the default screen of the controller and displays after the controller is powered up and the unit management software is loaded. It displays the controller mode, total operating hours, hours left until the next service interval, engine operating status, and engine RPM. If the unit is in AUTO mode, the Home screen may also display whether the scheduler or “dusk to dawn” are enabled.

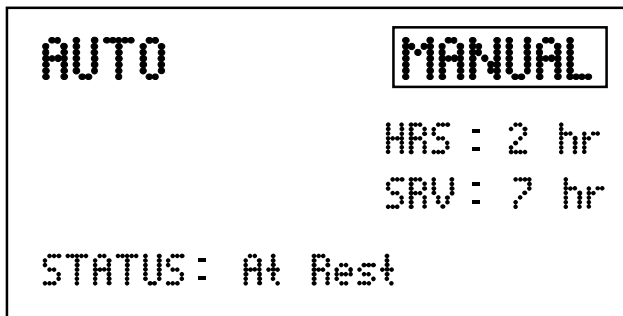

002544

Figure 2-7. Home Screen

Battery Voltage Screen

See [Figure 2-8](#). Displays the engine battery voltage. A normal reading is 12-14V on 12 volt systems (with the engine running).

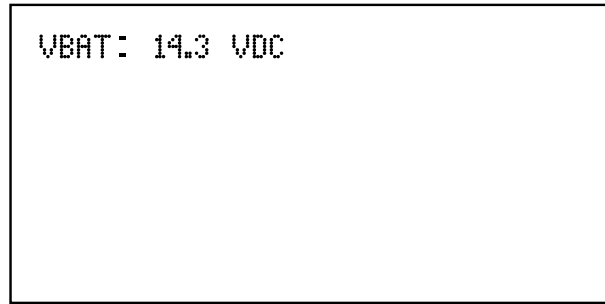

002990

Figure 2-8. Battery Voltage Screen

Lights Screen

See [Figure 2-9](#). The Lights screen enables the operator to turn the lights on and off. Refer to [Light Operation](#) for more information.

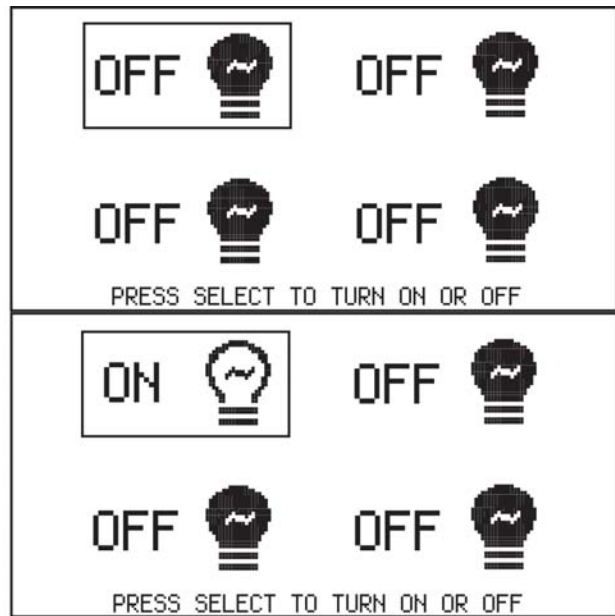

002327

Figure 2-9. Lights Screen

Line Amperage Screen

See [Figure 2-10](#). The Line Amperage screen displays the AC output amperage produced by the generator in Amps (A). The load balance for each line (L1 and L3) is displayed in both numerical and graphical form. It is important to maintain a balanced load distribution between lines for optimum generator performance.

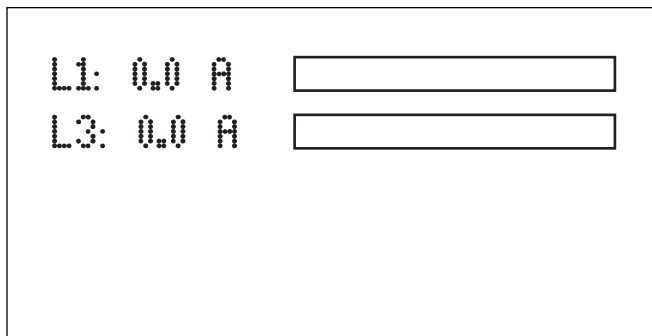

002980

Figure 2-10. Line Amperage Screen

Generator Screen

See [Figure 2-11](#). The Generator screen displays the average line voltage, frequency (in Hertz), and power factor for the generator while in operation.

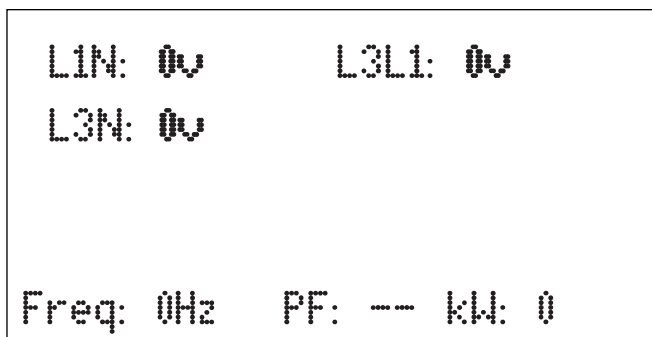

002981

Figure 2-11. Generator Screen

Dusk to Dawn Screen

NOTE: This feature will only work in AUTO mode.

See [Figure 2-12](#). The Dusk to Dawn screen enables or disables the “dusk to dawn” function. This function uses a photo sensor to detect the surrounding light level, automatically starting the engine and turning the lights on at dusk. The engine will run and the lights will remain illuminated until dawn.

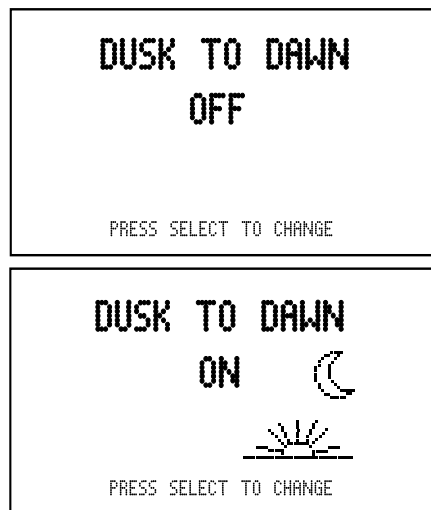

002328

Figure 2-12. Dusk to Dawn Screen

Scheduler Screen

NOTE: This feature will only work in AUTO mode.

See [Figure 2-13](#). The Scheduler screen enables the operator to program specific times for the lights to turn on and off. Once programmed, the Scheduler will start the engine and illuminate the lights until the designated shutdown time.

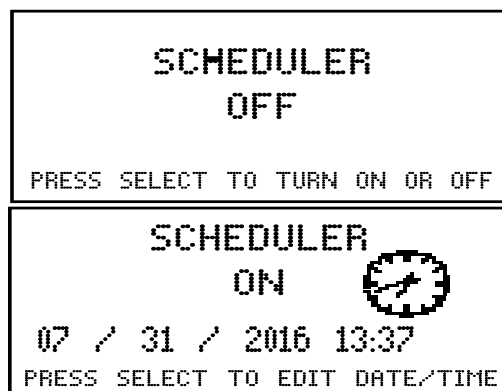

002329

Figure 2-13. Scheduler Screen

Maintenance Screens

See [Figure 2-14](#). The information displayed on the maintenance screens can be used to identify, diagnose and troubleshoot unit shutdown conditions and poor unit performance..

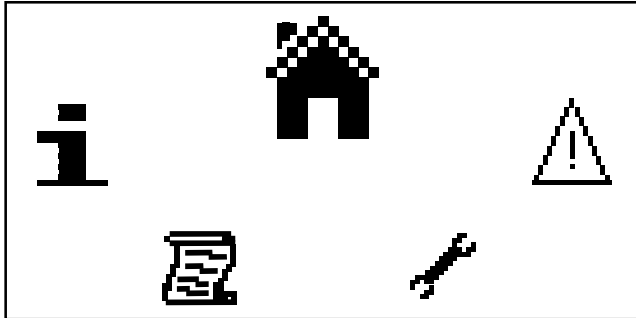

002329

Figure 2-14. Maintenance Screens

Icon	Description
	Home screen
	Alarms screen
	Maintenance screen
	Event log screen
	About screen

To enter the navigation menu, use the following procedure:

1. Press both the ↑ and ↓ buttons simultaneously.
2. To select the required icon, press the ↑ button to cycle right and the ↓ button to cycle left until the desired operator screen section is reached.
3. Once the desired icon is at the top, press the Select (✓) button to enter that operator screen section.

NOTE: Every time the operator screens are entered, the home icon will be located at the top of the screen.

Home Screen

See [Figure 2-15](#). The Home (🏠) screen is the default screen of the controller and displays after the controller has powered up. The controller automatically returns to Home from any other screen after a period of inactivity.

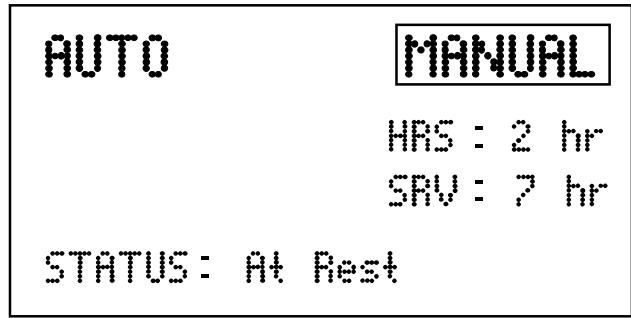

002544

Figure 2-15. Home Screen (MANUAL Mode Shown)

Alarms Screen

See [Figure 2-16](#). The Alarms (⚠️) screen displays all the alarms, warnings, and engine Diagnostic Trouble Code (DTC) faults. When an alarm occurs, the controller automatically switches to this screen and remains there until the alarm is cleared. The Stop LED also flashes.

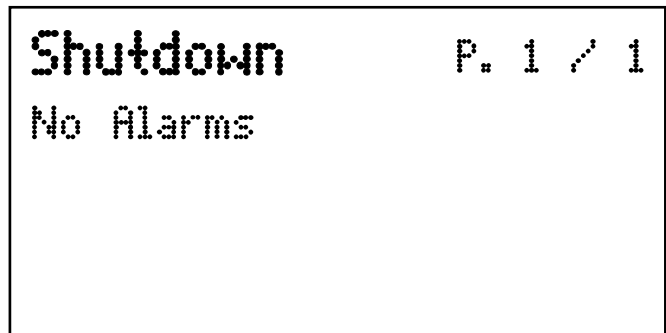

003780

Figure 2-16. Alarms Screen

- **Warnings** are non-critical alarm conditions and do not affect the operation of the generator system. They serve to draw the operator’s attention to an undesirable condition. By default, warning alarms are self-resetting when the fault condition is removed.
- **Electrical trips** stop the generator in a controlled manner. On initiation of the electrical trip condition, the controller de-energizes all the outputs, including the lights, to remove the load from the generator. Once this has occurred, the controller starts the cooling timer and allows the engine to cool off-load before shutting down the engine.
- **Shutdown alarms** stop the generator immediately. On initiation of the shutdown condition, the controller de-energizes all the outputs, including the lights, to remove the load from the generator.

Once this has occurred, the controller shuts the generator set down immediately to prevent further damage.

- **DTC faults** are displayed by the controller.

Table 2-1. Possible DTC Faults

Fault	DTC Description
Check Engine Fault	A fault not recognized by the controller has been detected. Contact the engine manufacturer for support.
Low Oil Pressure	Engine oil pressure has fallen below its configured low oil pressure alarm level.
Underspeed	Engine speed has fallen below its configured underspeed alarm level.
Overspeed	Engine speed has risen above its configured overspeed alarm level.
Low Fuel Level	Engine's fuel level has fallen below its configured low fuel level alarm.
Battery Under/Over Voltage	Engine's DC supply has fallen below or risen above its configured alarm level.

To view the active alarms, repeatedly press the ↑ and ↓ buttons until the LCD window displays the alarm.

Continue to press the ↑ and ↓ buttons to cycle through the alarms.

To exit the alarm screen, press the ↑ and ↓ buttons simultaneously to enter the navigation menu. Once entered, cycle to the desired operator screen.

NOTE: The alarm condition must be corrected before a reset will take place. If the alarm condition remains, it is not possible to reset the unit. The exception to this is the Low Oil Pressure alarm and similar 'active from safety on' alarms, as the oil pressure is low with the engine at rest.

To clear alarms that stop the generator, refer to [Resetting the Maintenance Alarms \(If Equipped\)](#).

NOTE: The LCD backlight is on if the unit has sufficient voltage while the unit is turned on, unless the unit is cranking. In this case, the backlight is turned off.

If the controller is left in STOP mode for a period of inactivity, the controller enters POWER SAVE mode. To 'wake' the controller, press the Stop (O) button.

Maintenance Screen

See [Figure 2-17](#). The Maintenance screen (🔧) displays the maintenance alarms configured into the controller. The three alarms are for servicing the fuel filter, oil filter, and air filter.

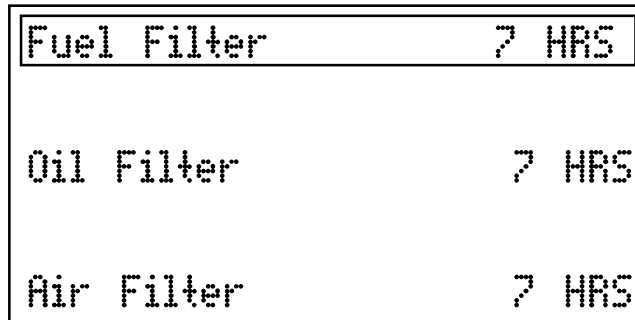

003781

Figure 2-17. Maintenance Screen

Event Log Screen

See [Figure 2-18](#). The controller's event log (📄) displays a list of the last 15 recorded electrical trips or shutdown events and the engine hours at which they occurred. Once the log is full, any subsequent electrical trip or shutdown alarm overwrites the oldest entry in the log. Therefore, the log always contains the most recent shutdown alarms.

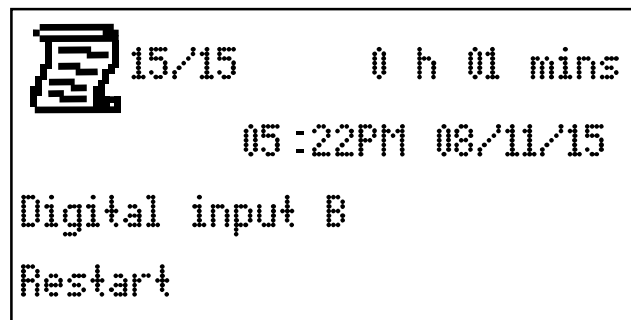

003782

Figure 2-18. Event Log Screen

To view the event log:

1. Press both ↑ and ↓ buttons simultaneously to display the navigation menu.
2. Cycle to the event log section and press the Auto button to enter.
3. Repeatedly press the ↑ or ↓ buttons until the LCD window displays the desired event.

Continuing to press down the ↑ or ↓ buttons will cycle through past alarms. Eventually the most recent alarm will display and the cycle begins again.

To exit the event log, press the ↑ and ↓ buttons simultaneously to enter the navigation menu. Once entered, cycle to the desired operator screen.

About Screen

See [Figure 2-19](#). The About (🔧) screen contains information about the controller such as the controller's date and time, the product and USB identification number, and the application and engine version.

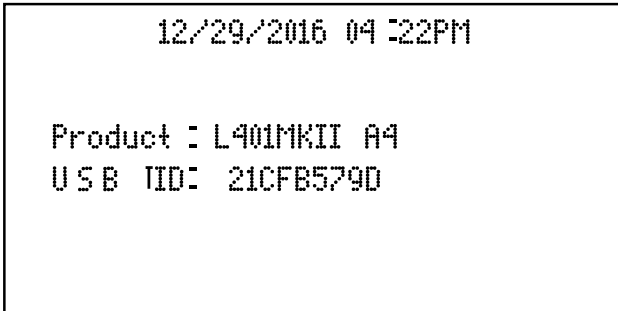

003783

Figure 2-19. About Screen

Section 3: Operation

Light Tower Setup

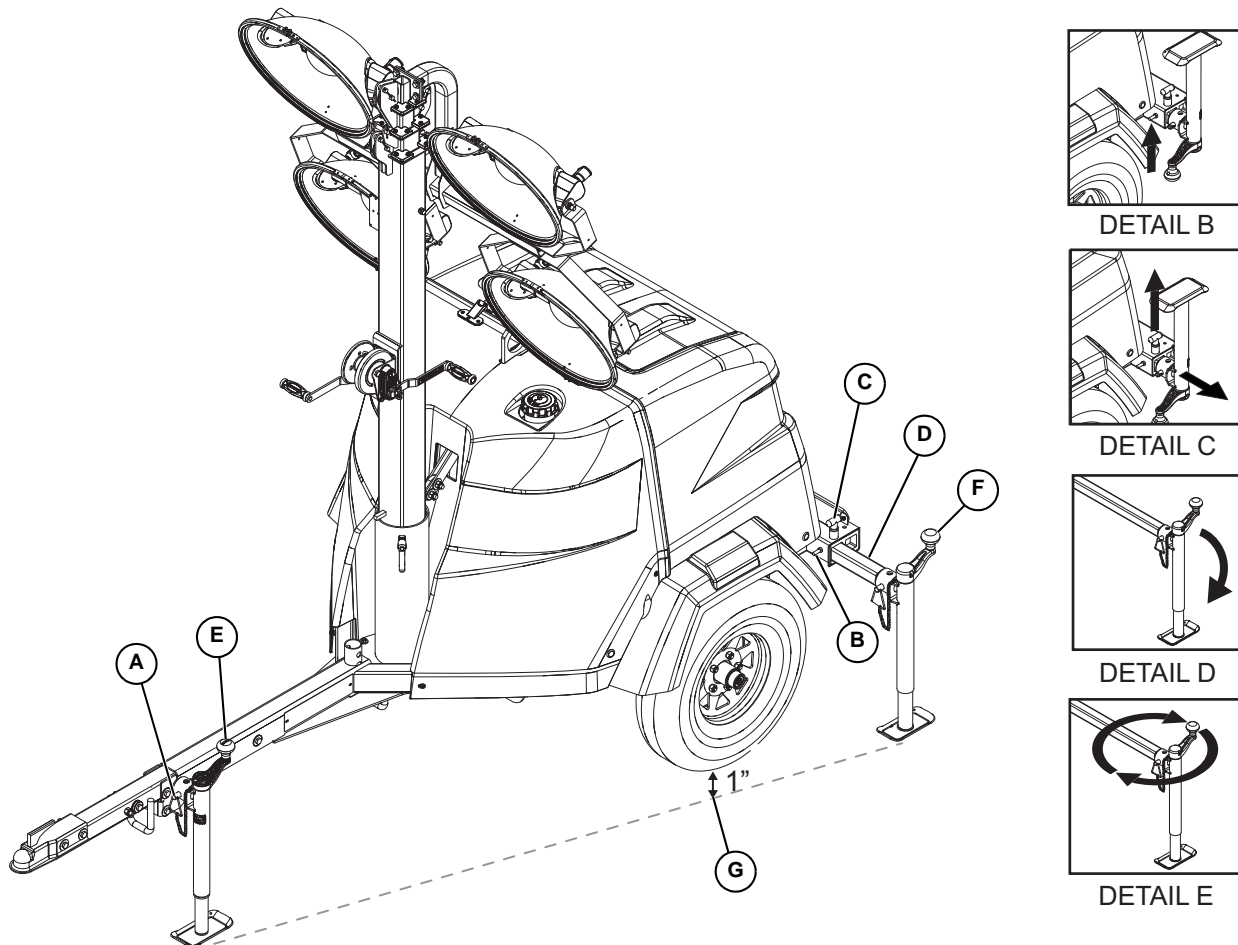

Figure 3-1. Set Up Outriggers and Jacks

006454



DANGER

High Voltage. Verify area above unit is clear of overhead wires and obstructions. Contact with high-voltage power lines will result in death or serious injury. (000260a)



WARNING

> 60 mph Do not set up the unit if high winds are expected. High winds can cause the unit to tip or fall, causing severe injury or machine damage. (000297)

1. For maximum light coverage, position the unit at ground level or in a spot higher than the area being illuminated by the lamps.

NOTE: The mast extends up to 23 ft (7m).

2. See **Figure 3-1**. Place the unit on firm ground that is relatively flat (less than 5° slope), and then block the wheels to keep it from moving. This will make it easier to level the unit.
3. Pull the locking pin (A) on the tongue jack (E) and rotate the jack 90°. Reinstall the locking pin. Rotate the jack handle clockwise to raise the trailer tongue off the towing vehicle.
4. A grounding stud (B) is located on the rear frame of the trailer near the left side outrigger. For grounding requirements, follow local, state, and National Electrical Code (NEC) regulations.
5. See Details C—D. Pull the locking pins (C) on the outriggers (D) and pull each outrigger out until the spring loaded locking pin snaps back into place. Pull the locking pin on each outrigger jack (F) and rotate each jack 180° so the jack pad is facing down. Reinstall the locking pin.

6. See Detail E. Rotate each jack handle clockwise to start leveling the trailer. Adjust all three jacks by rotating their handles clockwise until they are firmly in contact with the ground. Continue until the wheels are approximately one inch (2.5 cm) off the ground (G).
7. Before raising the mast, it may be necessary to adjust the lamps. The lamps may be adjusted up, down, left or right by simply aiming them in the desired direction.

Prestart Checklist

Before starting the unit, all items in the prestart checklist must be completed. This checklist applies to both manual and remote starting of the unit.



⚠️ WARNING

Consult Manual. Read and understand manual completely before using product. Failure to completely understand manual and product could result in death or serious injury. (000100a)

- Verify all maintenance procedures are up to date. For more information, refer to **General Maintenance** and **Basic Maintenance Schedule**.
- The unit must be level.
- The unit must be dry. Look for water inside or near the unit; dry if needed.
- For grounding requirements, follow the local, state, or National Electrical Code (NEC) regulations.
- Verify the Control Power switch is in the OFF (O) position.
- Verify all circuit breakers are in the OFF (O) position.
- Inspect all electrical cords; repair or replace any that are cut, worn, or bare.
- Verify all winch cables are in good condition and centered on each pulley. Do not use if cables are kinked or beginning to unravel.
- Check oil, coolant, and fuel levels. For more information, refer to **General Maintenance**.
- Verify battery connections are secure.
- Turn the battery disconnect switch on, if equipped.
- Check the engine fan belt tension and condition.
- Check the engine fan belt guard.
- Check the engine exhaust system for loose or rusted components.
- Verify all covers are in place and secure.

Raising the Mast—Manual Winch

1. Set up and level the unit. See **Light Tower Setup**.



⚠️ DANGER

Electrocution. DO NOT use the unit if electrical cord is cut or worn through. Doing so will result in death or serious injury. (000263a)

⚠️ WARNING

Tipping hazard. Extend the outriggers and level the unit before raising the mast. Keep the outriggers extended while the mast is up. Failure to do so could cause the unit to tip and fall and could result in death or serious injury. (000266)

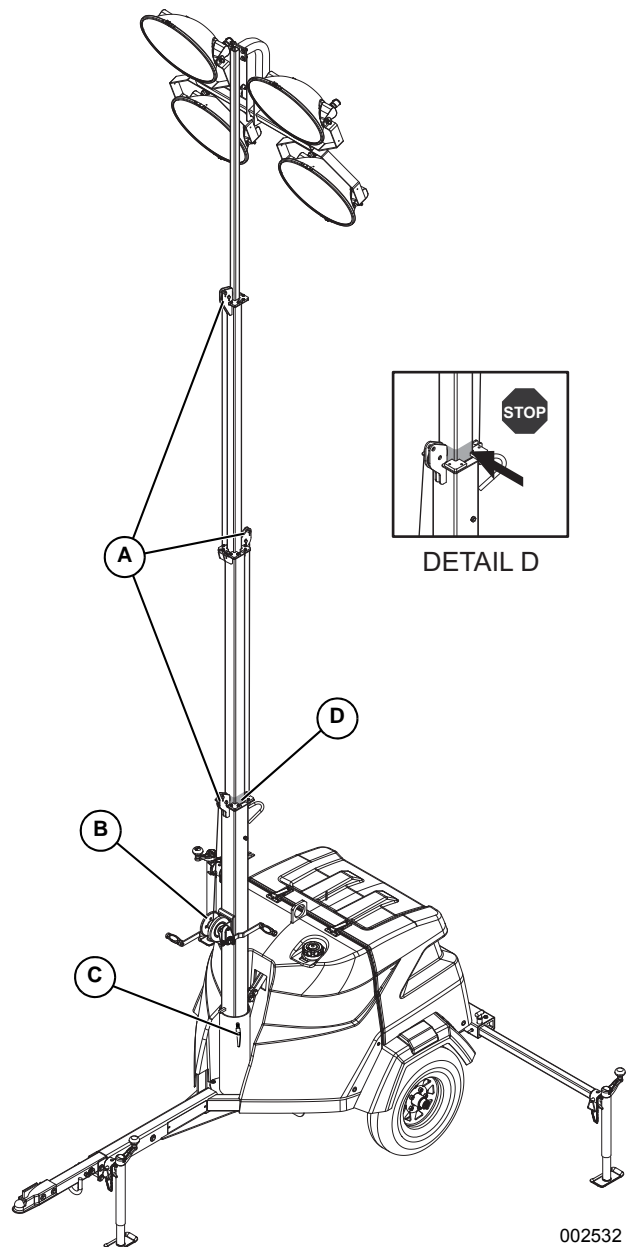

Figure 3-2. Pulley Locations - Manual Winch

2. See [Figure 3-2](#). Check the mast cables for excessive wear or damage. Verify the cables are properly centered in each pulley (A). Check the electrical cord for damage.
3. Rotate the mast by loosening the mast rotation knob (C) at the bottom of the mast. Turn the mast until the lights face in the desired direction, and then tighten the mast rotation knob to secure the mast in position.
4. Using both hands, rotate the winch (B) to slowly extend the mast, making sure that the coiled electrical cord is extending at the top sections of the mast. STOP extending the mast when the colored mark (D) on the second mast section is visible as seen in Detail D.

⚠ WARNING

Tipping hazard. Do not extend the mast beyond the colored mark on the second mast section. The unit can become unstable and tip or fall, causing injury.

(000262)

⚠ WARNING

Personal Injury. Stop immediately if the mast hangs up or the winch cable develops slack. Excess slack could cause the mast to collapse, resulting in personal injury or equipment damage.

(000265)

⚠ WARNING

Personal injury or equipment damage. Do not raise or lower the mast while the unit is operating. Doing so can break the lenses and cause the lamps to shatter.

(000279)

IMPORTANT NOTE: Contact a Generac Mobile Products Authorized Service Dealer immediately if the mast hangs up or the winch cable develops slack.

Raising the Mast—Electric Winch (If Equipped)

1. Set up and level the unit. See [Light Tower Setup](#).



⚠ DANGER

Electrocution. DO NOT use the unit if electrical cord is cut or worn through. Doing so will result in death or serious injury.

(000263a)

⚠ WARNING

Tipping hazard. Extend the outriggers and level the unit before raising the mast. Keep the outriggers extended while the mast is up. Failure to do so could cause the unit to tip and fall and could result in death or serious injury.

(000266)

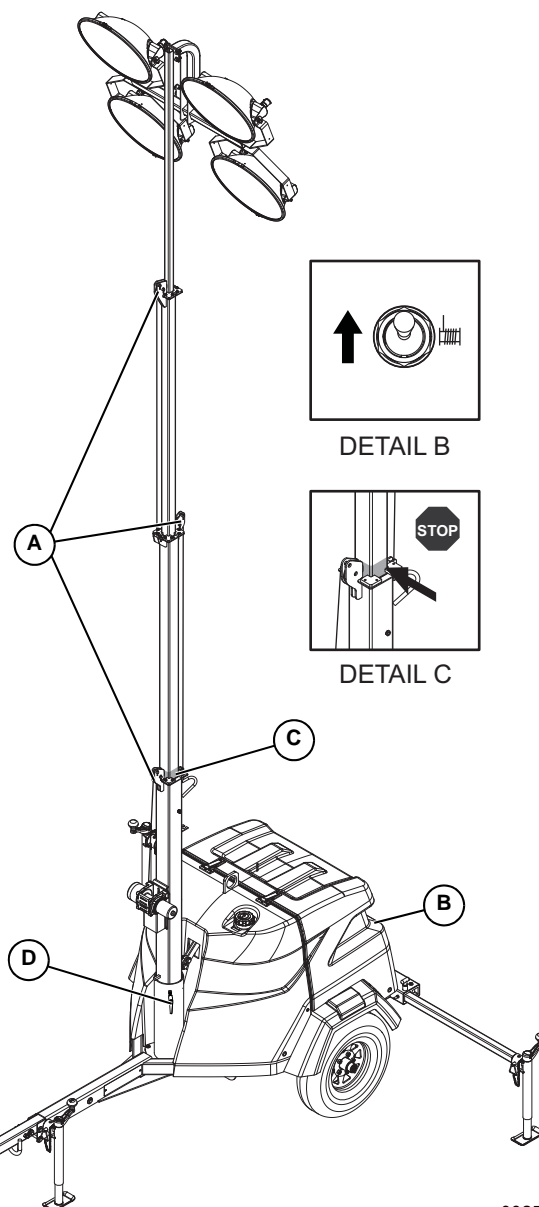

002533

Figure 3-3. Switch & Pulley Locations - Electric Winch

2. See **Figure 3-3**. Check the mast cables for excessive wear or damage. Verify the cables are properly centered in each pulley (A). Check the electrical cord for damage.
3. Rotate the mast by loosening the mast rotation knob at the bottom of the mast (D). Turn the mast until the lights face in the desired direction and then tighten the mast rotation knob to secure the mast in position.
4. Start unit according to **Manually Starting the Unit**.
5. Press and hold the winch control switch (Detail B) upward to telescope the mast to the desired height. While doing so, verify that the coiled electrical cord is extending at the top sections of the mast. STOP extending the mast when the colored mark (C) on the second mast section is visible as seen in Detail C.

IMPORTANT NOTE: A limit switch on the main mast section will disconnect power to the upper electric winch to prevent overextending the mast.

WARNING

Tipping hazard. Do not extend the mast beyond the colored mark on the second mast section. The unit can become unstable and tip or fall, causing injury.

(000262)

WARNING

Personal Injury. Stop immediately if the mast hangs up or the winch cable develops slack. Excess slack could cause the mast to collapse, resulting in personal injury or equipment damage.

(000265)

WARNING

Personal injury or equipment damage. Do not raise or lower the mast while the unit is operating. Doing so can break the lenses and cause the lamps to shatter.

(000279)

IMPORTANT NOTE: Contact a Generac Mobile Products Authorized Service Dealer immediately if the mast hangs up or the winch cable develops slack.

Starting the Unit

NOTE: If the engine was run out of fuel or the fuel tank was drained, it may be necessary to bleed the fuel lines. Refer to the engine operator's manual supplied with the unit.

1. See **Figure 3-4**. Verify the main circuit breaker and individual circuit breakers for each of the lights are OFF (O).

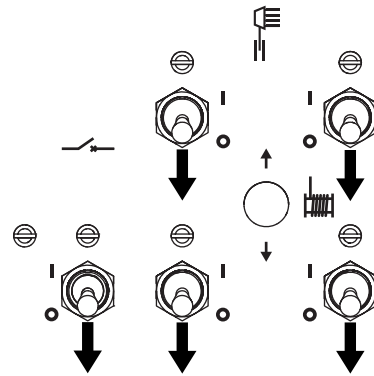

002752

Figure 3-4. Circuit Breakers in OFF (O) Position

2. See **Figure 3-5**. Turn the key on the Engine Start switch to the right GLOW PLUG position and hold the key in place for five seconds.

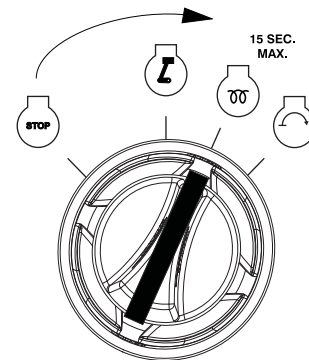

Figure 3-5. Activate Glow Plug

3. See **Figure 3-6**. Turn the key to the right START position and hold it until the engine cranks and starts running.

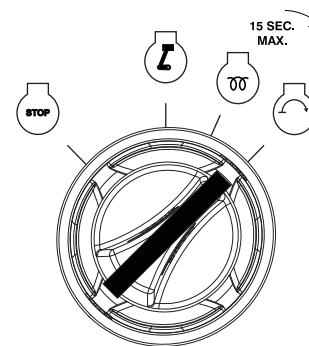

Figure 3-6. Crank Engine

- See [Figure 3-7](#). Release the key, it will move to the RUN position.



Equipment Damage. Do not continuously crank engine for more than ten seconds. Doing so will lead to overdischarge of batteries and starter seizure.

(000230)

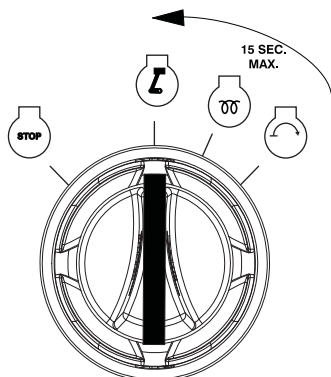

Figure 3-7. Release Key

Preparing for Start-Up (with Power Zone Controller, If Equipped)

NOTE: If the engine was run out of fuel or the fuel tank was drained, it may be necessary to bleed the fuel lines before starting. Refer to the engine manual supplied with the unit.

Select AUTO or MANUAL Mode

See [Figure 3-8](#). Using the arrows on the Power Zone–DLA, select either AUTO or MANUAL on the Home screen.

- AUTO mode is required for programming automatic start and stop times (see [Scheduler Screen](#)), or enabling the “dusk to dawn” sensor (see [Dusk to Dawn Sensor](#)).
- MANUAL mode is used for on-demand control of the lights and convenience outlets.

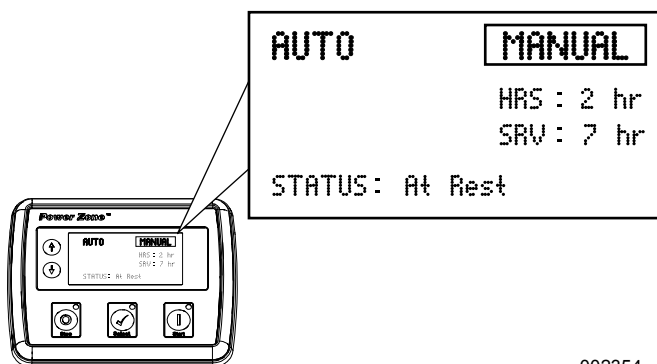

002354

Figure 3-8. Select AUTO or MANUAL Mode

Manually Starting the Unit

STOP mode is the default start-up setting for all units equipped with the Power Zone–DLA. Use the following procedure to start the generator in MANUAL mode.

- Verify the 240VAC outlet breaker is switched OFF (O).
- Switch the main circuit breaker ON (I).
- Verify that the Load Sense switch is OFF.
- When the controller powers up, the Home screen displays on the LCD screen and the Stop LED illuminates to indicate that the controller is in STOP mode. Press the Start button to initiate the startup procedure. Assuming there are no existing engine faults, the engine will start and the Start LED will illuminate.

NOTE: The engine can be started from any screen. It may take a few seconds for the engine to run smoothly and reach its governed operating speed.

- If the engine does not start after the first cranking attempt, the engine will pause for 15 seconds to allow the starter to cool. The controller backlight will go out. The engine will make two more attempts to start for a total of three crank cycles.
- If the engine does not start and run within three starting cycles, the LCD screen will display the “Fail to Start” alarm. The starting sequence can be repeated after the starter cools for at least two minutes. Pressing the Stop (O) button will clear the alarm and reset the controller.

Light Operation



Burn hazard. Never operate lights with a damaged or missing lens cover. Lamps are hot and pressurized while in use. Unprotected lamps can shatter, causing severe injury.

(000277)

- Verify the unit is ON and running smoothly.
- See [Figure 3-9](#). Switch the main circuit breaker (A) ON (I).
- Switch the individual circuit breakers for the lights (B) ON (I), one at a time.
- The ballast indicator lights will turn on and continue to get brighter as the lights warm up, and then remain on. This confirms power is coming from the ballasts to the lights.

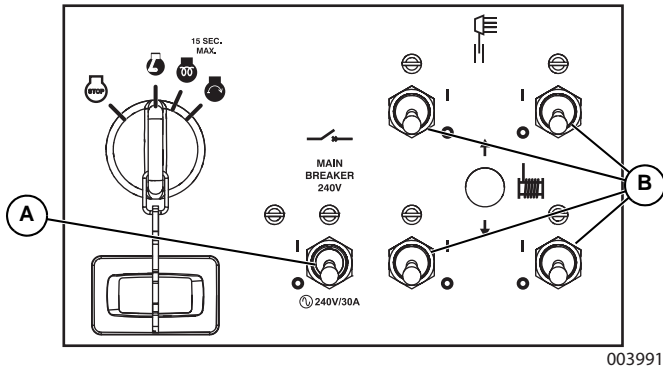



Figure 3-9. Light Switches and Breaker

NOTE: If an indicator light does not turn on, see [Troubleshooting](#) or contact a Generac Mobile Products Authorized Service Dealer.

NOTE: The lights require a warm up period of 5-15 minutes before they reach full output. If the lights are shut down, they require a cool down period of approximately ten minutes before they can be switched on again.

NOTE: The light tower uses four 1000W or 1050W bulbs. When checking or replacing the bulbs, wipe them with a clean cloth to avoid leaving any grease, oil residue or fingerprints on the glass. Any residue can create a hot spot on the bulb, causing premature bulb failure.

 **WARNING**
 Burn hazard. Lamps become extremely hot while in use. Allow 10–15 minutes for cooling before handling or lowering mast. Touching a hot lens or fixture can cause severe burns.
 (000278)

Light Operation (With Power Zone Controller, If Equipped)

See [Figure 3-10](#). The lights are turned on and off using the Power Zone–DLA. To view the light screen, press the ↑ button three times from the Home screen.

NOTE: The lights can only be turned ON and OFF while the unit is running in MANUAL mode. They operate automatically in AUTO mode.

1. Once the engine is up to temperature and running smoothly, switch the main circuit breaker ON (I).

To turn the light(s) ON, press the Select (✓) button. To turn the light(s) OFF, press the Select (✓) button.

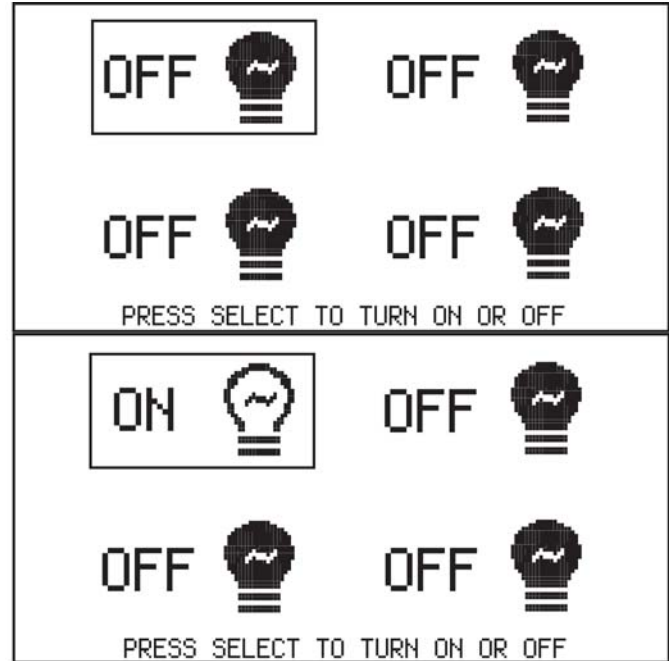



Figure 3-10. Lights Screen

 **WARNING**
 Burn hazard. Lamps become extremely hot while in use. Allow 10–15 minutes for cooling before handling or lowering mast. Touching a hot lens or fixture can cause severe burns.
 (000278)

Engine Derating

All units are subject to derating for altitude and temperature. Derating reduces the available power for operating tools and accessories connected to the outlets. For every increase in 1000 ft (305 m) of elevation, engine performance for this unit typically drops between 2% and 4%. Also, engine performance decreases about 1% for every 10°F (5.6°C) increase in ambient air temperature over 72°F (22°C).

Wet Stacking

The unit is powered by a diesel engine. Diesel engines are subject to “wet stacking” if lightly loaded. Wet stacking occurs when an engine is run at less than 30% of its full load capacity, causing unburned fuel to accumulate in the exhaust system. Wet stacking can be detected by continuous black exhaust when the unit is under a constant load. It can also cause fouling of injectors and buildup on engine valves. Diesel engines operate properly when applied loads are between 30% and 100% capacity. Appropriate generator sizing is

determined by the anticipated load. If the unit is in a wet stack condition, load the unit heavily for five hours or until the exhaust is clear.

Dusk to Dawn Sensor

This unit is equipped with a “dusk to dawn” photo sensor to detect the surrounding light level, automatically starting the engine and turning the lights on at dusk. The engine will run and the lights will remain illuminated until dawn.

To prepare the sensor for use, perform the following procedure at the time of day you want the lights to turn on:

1. Verify the Power Zone–DLA is set up and the unit is ON.
2. Slide the light shield bracket up, decreasing the sensor’s exposure to light, until the lights turn ON.
3. Tighten screws on shield.

Customer Convenience Outlets

See [Figure 3-11](#). The unit is equipped with convenience receptacles for powering accessories or tools from the generator. Power is supplied to the receptacles any time the engine is running and the main circuit breaker is switched to the ON (I) position. Each outlet has an individual circuit breaker, located on the control box. Refer to [Control Panel](#).

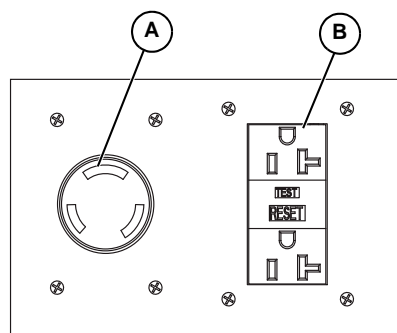

002535

Figure 3-11. Convenience Outlets

The circuit breakers are labeled with the corresponding voltage for the receptacle they protect. The standard receptacle panel is equipped with the following receptacles:

- One 240V/30A Twist-lock (A)
- One 120V/20A GFCI (B)

NOTE: Do not draw more than 1000W from each receptacle when the lights are on. This will overload the generator and cause the main circuit breaker to trip. Should the breaker trip, switch off the lights, remove some of the loads connected to the receptacles and wait ten minutes for the bulbs to cool before turning them back on.

With all of the lights OFF, the full generator output may be used with the 240V twist-lock receptacle.

Shutting Down the Unit

Check with personnel using power supplied by the unit and let them know the power is going to be turned off. Make sure the power shutdown will not create any hazards by accidentally turning off equipment that needs to remain running (pumps, compressors, lights, etc.).

1. Remove all loads from the outlets.
2. Switch the individual circuit breakers for each light OFF (O).
3. Switch the main circuit breaker OFF (O).
4. Move the control power switch to STOP.

Shutting Down the Unit (with Power Zone Controller, If Equipped)

Check with personnel using power supplied by the unit and let them know the power is going to be turned off. Verify the power shutdown will not create any hazards by accidentally turning off equipment that needs to remain running (pumps, compressors, lights, etc.).

1. Remove all loads from the outlets.
2. Turn the lights OFF using the controller.
3. Switch the outlet breaker OFF (O).
4. Press the Stop (O) button.
5. After the unit shuts down, switch the main circuit breaker OFF (O).

NOTE: Disconnect the battery if the unit is to be stored for an extended period. Refer to the engine operator’s manual for additional extended storage procedures.

Automatic Shutdown

This unit is equipped with a low oil pressure and high coolant temperature automatic shutdown system. This system will automatically shut off the fuel supply to stop the engine if oil pressure drops too low or the engine exceeds normal operating temperature. Return the main circuit breaker to the STOP position to reset the unit after the cause of shutdown has been determined.

Lower Radiator Hose Heater (If Equipped)

The lower radiator hose heater is designed to prevent engine coolant from freezing in extreme cold weather conditions. While the heater is designed to be operated overnight if necessary, two to five hours of heating just prior to starting is usually sufficient for proper engine starting.

NOTE: Use the lower radiator hose heater only in its designated location. Improper use can damage the engine.

Perform the following steps when operating a unit equipped with a lower radiator hose heater.

1. Verify that the unit is level so as to maintain proper orientation of the heater while it is in operation.
2. Verify that the cooling system is full of the proper mixture of water and engine coolant before each heater use.
3. Use only an undamaged, outdoor rated, three-prong grounded 120VAC extension cord with a minimum amperage rating of 10A. Connect the cord to a properly grounded 120VAC, GFCI outlet.
4. Before starting the engine, unplug the extension cord from the power first, then unplug the heater cord set from the extension cord.

Tandem Tow (If Equipped)

The tandem tow hitch option (A) allows the operator to tow a second MLT6 Light Tower in series behind the unit equipped with the hitch.

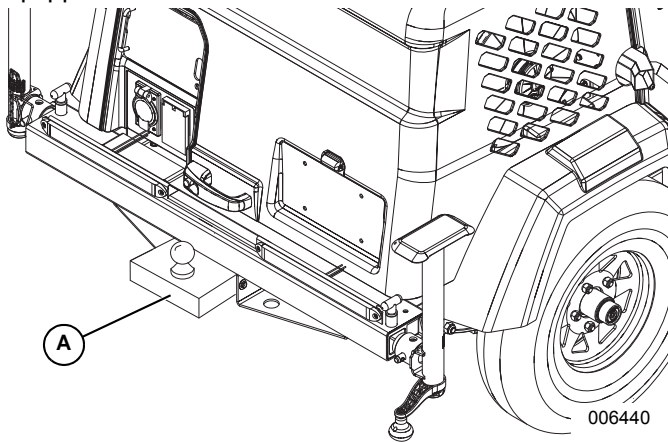

Figure 3-12. Tandem Tow

Telemetry (If Equipped)

The digital telemetry option enables the operator to remotely monitor the unit fuel level. A transmitter inside the engine compartment sends real time equipment status information to the user via cellular or satellite connection.

Spark Arrester (If Equipped)

A spark arrester, installed on the MLT exhaust, may be required by code in certain municipalities. Check with the local authority having jurisdiction to determine whether or not a spark arrester must be installed on the unit before operation.

Lowering the Mast—Manual Winch



WARNING

Burn hazard. Lamps become extremely hot while in use. Allow 10–15 minutes for cooling before handling or lowering mast. Touching a hot lens or fixture can cause severe burns.

(000278)

1. Shut down the lights and engine. See [Shutting Down the Unit](#).
2. Lower the mast.
3. Use the winch handles to collapse the mast to its lowest position. Ensure the electrical cord does not get caught in, or pinched by, the mast while it is being lowered.

WARNING

Personal Injury. Stop immediately if the mast hangs up or the winch cable develops slack. Excess slack could cause the mast to collapse, resulting in personal injury or equipment damage.

(000265)

IMPORTANT NOTE: Contact a Generac Mobile Products Authorized Service Dealer immediately if the mast hangs up or the winch cable develops slack.

4. See [Figure 3-13](#). If the unit is going to be moved, rotate the mast so the lights face the rear of the unit.

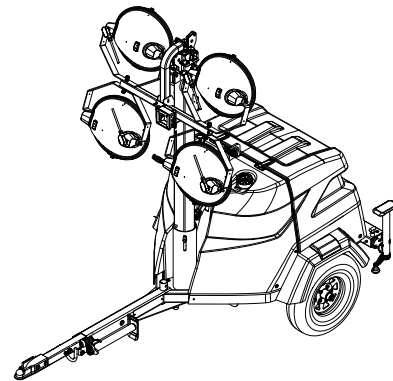

Figure 3-13. Stowed (Travel) Position

To rotate the mast:

- a. Loosen the mast rotation knob.
- b. Rotate the mast until the white arrows are aligned and the metal stop tabs are touching.
- c. Tighten the mast rotation knob.

Lowering the Mast—Electric Winch (If Equipped)



WARNING

Burn hazard. Lamps become extremely hot while in use. Allow 10–15 minutes for cooling before handling or lowering mast. Touching a hot lens or fixture can cause severe burns.

(000278)

1. Press and hold the upper winch control switch downward to collapse the mast to its lowest position. Ensure the electrical cord does not get caught in, or pinched by, the mast while it is being lowered.
2. Shut down the lights and engine. See [Shutting Down the Unit](#).
3. If the unit is going to be moved, rotate the mast so the lights face the rear of the unit. To rotate the mast:
 - a. Loosen the mast rotation knob.
 - b. Rotate the mast until the white arrows are aligned and the metal stop tabs are touching.
 - c. Tighten the mast rotation knob.

NOTE: Some electric winch models are equipped with an anti-backlash safety limit switch. This switch disconnects power to the winch after the mast is completely lowered. This prevents the cable from continuing to unwind and becoming entangled around the winch drum.

WARNING

Personal Injury. Stop immediately if the mast hangs up or the winch cable develops slack. Excess slack could cause the mast to collapse, resulting in personal injury or equipment damage.

(000265)

IMPORTANT NOTE: Contact an Generac Mobile Products Authorized Service Dealer immediately if the mast hangs up or the winch cable develops slack.

NOTE: If the generator is not operational, and the batteries do not have enough power to lower the mast, it may be necessary to lower the mast manually. Always attempt to recharge the batteries and lower the mast electrically before proceeding.

Manually Lowering the Mast

IMPORTANT NOTE: Do not use this procedure unless it is absolutely necessary. Frequent use of this procedure could damage the motor shaft.

1. See [Figure 3-14](#). Remove the motor cover (A).

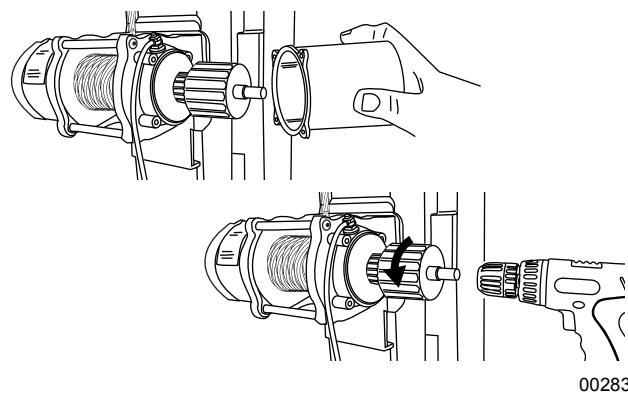

Figure 3-14. Manually Lowering the Mast

2. Attach a drill chuck firmly to the exposed motor shaft (B).
3. Using the drill, slowly rotate the motor shaft counterclockwise to lower mast.
4. Detach the drill chuck and install the motor cover after the mast is completely lowered.

Towing the Unit

Once the engine is shut down and the mast and lights are properly stowed, follow these steps to prepare the unit for towing.

1. Raise the outrigger jacks completely and release the locking pins to rotate them up into the travel position. Make sure the locking pins snap into place. Release the outrigger locking pins and slide the outriggers into the trailer frame until the locking pins snap into place.
2. Use the tongue jack to raise or lower the trailer onto the hitch of the towing vehicle. Lock the hitch coupling and attach the safety chains or cables to the vehicle. Remove the tongue jack locking pin and rotate the jack into the travel position. Replace the locking pin.
3. To ensure proper operation of the jacks, lubricate the grease fittings located on the leveling jacks. Refer to [Jack Maintenance](#). For maintenance interval information, refer to [Basic Maintenance Schedule](#).
4. Connect any trailer wiring to the tow vehicle. Check for proper operation of the directional and brake lights.
5. Verify the enclosure is properly latched.
6. Check for proper inflation of the trailer tires. For maximum tire pressures, refer to [Specifications](#).
7. See [Figure 3-15](#). Check the wheel lugs. Tighten or replace any lugs that are loose or missing. If a tire has been removed for axle service or replaced, tighten the lugs, in the order shown, to the following specifications:

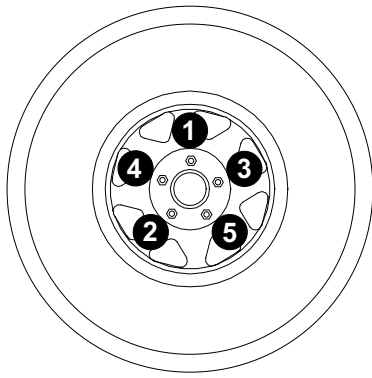

003754

Figure 3-15. Tightening Wheel Lugs

- a. Start all lug nuts by hand.
- b. First pass: tighten to 20-25 ft-lbs (27-33 Nm).
- c. Second pass: tighten to 50-60 ft-lbs (67-81 Nm).
- d. Third pass: tighten to 90-120 ft-lbs (122-162 Nm).

NOTE: After the first road use, re-torque the lug nuts in sequence.

8. Maximum recommended speed for highway towing is 45 mph (72 km/h). Recommended off-road towing speed is not to exceed 10 mph (16 km/h) or less, depending on the terrain.

Lifting the Unit

Follow these steps to prepare the unit for lifting:

1. Verify the equipment being used to lift the unit is in good condition and has sufficient capacity. For approximate weights, refer to [Specifications](#).
2. Close and lock all hoods and doors.
3. See [Figure 3-16](#). Stow the mast and lights in the travel position as shown.
4. Always remain aware of people and objects around the unit while preparing, maneuvering, and lifting the unit.
 - When lifting the unit, attach any slings, chains or hooks directly to the central lift point (A). The central lift point is located on top of the enclosure, connected to a lift structure inside the unit.

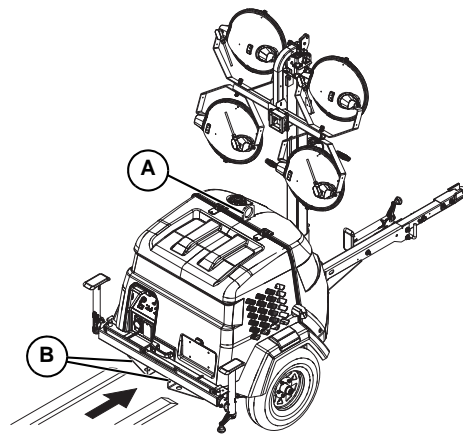

006456

Figure 3-16. Lifting Point

Use the forklift pockets (B) with care. Lift directly from the rear. Avoid approaching the unit at an angle, as this can permanently damage the forklift pockets, tires, or cabinet. Verify any obstructions are clear of the forklift tines before lifting.

Tying the Unit Down

When securing the unit for transportation, verify the equipment being used to fasten the unit is in good condition and has sufficient strength to hold the unit in place during transport.

See [Figure 3-17](#). Use the tie-down points (C) as shown.

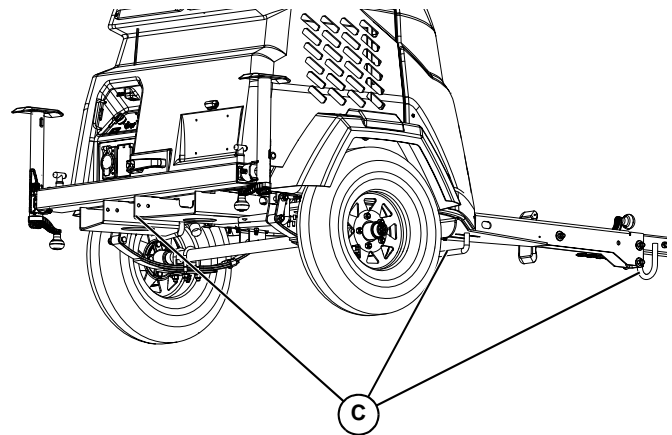

002537

Figure 3-17. Tie-Down Points

Section 4: Maintenance

Emissions Information

For warranty information, please refer to the diesel engine manual supplied with this unit.

Daily Walk-Around Inspection

Perform a walk-around inspection of the unit every day before starting the unit. Look for conditions that could hinder performance or safety, such as (but not limited to):

- Oil, coolant and fuel leakage
- Blocked vents
- Loose or missing hardware
- Loose or broken electrical connections.

Inspect the fan belt for cracks, fraying, or stretching. Verify the belt is properly seated in the pulley grooves. Replace the belt according to the manufacturer's recommendations.



Equipment Damage. Failure to perform a daily inspection could result in damage to the unit.

(000306)

General Maintenance

Poorly maintained equipment can become a safety hazard. In order for the equipment to operate safely and properly over a long period of time, periodic maintenance and occasional repairs are necessary. **DO NOT** perform routine service (oil and filter changes, cleaning, etc.) unless all electrical components are shut off.

Regular maintenance will improve performance and extend engine/equipment life. Generac Mobile Products LLC recommends that all maintenance work be performed by a Generac Mobile Products Authorized Service Dealer. Regular maintenance, replacement or repair of the emissions control devices and systems may be performed by any repair shop or person of the owner's choosing. However, to obtain emissions control warranty service free of charge, the work must be performed by a Generac Mobile Products Authorized Service Dealer or authorized Mitsubishi engine dealer depending on the repair. See the emissions warranty.

Preparing for Service

Before servicing the unit, always follow the instructions listed below.

1. If unit is equipped with the Power Zone controller, verify the main circuit breaker is OFF. Otherwise, verify the key switch is in the OFF position.
2. Verify the circuit breakers are switched OFF (O).

3. Disconnect the negative (–) terminal on the battery.
4. Attach a "Do Not Start" sign to the control panel. This will notify everyone that the unit is being serviced and will reduce the chance of someone inadvertently trying to start the unit.

Cleaning the Unit

Always clean the Light Tower after each use to remove dust, grease, mud, or spilled fuel or oil. Use soft, clean rags to wipe the cabinet exterior and control panel. Low-pressure compressed air (less than 40 PSI [276 kPa]) can also be used to remove dust and debris from the cabinet interior.

This unit contains sensitive electronic components that can be damaged by high pressure and heat. Therefore:

- Do not wash the unit with a high pressure hose or power washer.
- Do not wash the engine block or fuel tank with a power washer or steam cleaner. Water may enter the cabinet and collect in the generator windings or other electrical parts, causing damage.

Inspecting the Unit

- If the unit is stored outside, check for water inside the cabinet and generator before each use. If wet, dry the unit thoroughly before starting.
- Inspect condition of electrical cords. **DO NOT** use the unit if insulation is cut or worn through.
- Verify winch cables are in good condition and centered on each pulley. **DO NOT** use a cable that is kinked or starting to unravel.
- Verify the safety pins for the mast lock rod and mast lock bar are present and secured with a chain. Check that the spring located in the mast lock bar is not broken or missing. Check the operation of the mast lock bar.
- Verify the wheel lugs are present and properly tightened. Refer to [Towing Safety](#).
- Check the coolant level daily by inspecting the level in coolant overflow jug located near the radiator. Refer to the engine operator's manual for coolant recommendations and proper mixture. Normal operating level is between the 'full' and 'add' markings on the overflow jug.
- **AFTER ENGINE IS STOPPED AND COMPLETELY COOL**, coolant may be added directly to the coolant overflow jug.
- Check the oil level daily. Refer to the engine operator's manual for the appropriate oil specification.

Verify the oil is correct for special operating conditions such as a change in season or climate.

- **DO NOT** start the unit if the engine oil level is below the ADD mark on the dipstick.
- Normal operating level is in the cross-hatch pattern between the full and add markings on the dipstick.
- Add oil only if the oil level is below the add mark on the bottom of the cross-hatch pattern on the dipstick. **DO NOT OVERFILL** the crankcase.
- Check the fuel level.
- If the unit is connected to a remote start or transfer switch, make sure the remote switch is also off and tagged.

NOTE: If the engine was run out of fuel or the fuel tank was drained, it may be necessary to bleed the fuel lines. Refer to the engine operator's manual supplied with the unit.

Basic Maintenance Schedule

Refer to the original equipment manufacturer's operating manual for a complete list of maintenance requirements. Failure to comply with the procedures as described in the engine operator's manual will nullify the warranty, decrease performance and cause equipment damage or premature equipment failure. Maintenance records may be required to complete a warranty request.

Use the schedule in the following table as a guide for regular maintenance intervals. For additional or replacement copies of the engine operator's manual, contact a Generac Mobile Products Authorized Service Dealer.

Table 4-1. Basic Maintenance Guide

Item	Daily	Every 50 Hours	Every 250 Hours	Every 500 Hours	Every 1000 Hours	Every 2000 Hours
Check Oil Level	◆					
Check Coolant Level	◆					
Check Fuel Level	◆					
Check Tire Pressure	◆					
Inspect Wheel Bearings	◆					
Check Belt for Wear and Looseness	◆					
Check All Electrical Connections	◆					
Inspect Radiator Fins For Debris; Clean As Required	◆					
Inspect Light Tower Winch For Proper Operation	◆					
Check Fuel and Coolant Clamps for Tightness		◆*				
Drain Water Separator		◆				
Sample Coolant			◆			
Inspect and Adjust Fan Belt			◆			
Sample Engine Oil			◆			
Clean / Replace Air Filter Element			◆			
Replace Fuel System Secondary Filter				◆		
Change Engine Oil and Filter				◆		
Check Engine Sensors (Oil Pressure and Coolant Temperature)				◆		
Lubricate Leveling Jacks				◆		
Inspect Hoses and Clamps				◆		
Clean Radiator				◆		
Replace Alternator and Fan Belts					◆	
Adjust Valve Clearance					◆	
Inspect Engine Mounts						◆
Replace Engine Breather						◆
Inspect Alternator						◆
Inspect Starter						◆

* *Inspect after first 50 hours*

Resetting the Maintenance Alarms (If Equipped)

The Power Zone controller will display a warning message when the unit is due for maintenance or service. The maintenance or service interval is set at 750 hours of engine running time. Once the unit has been serviced, the appropriate maintenance alarm reminder needs to be reset. The following procedure demonstrates how to reset the maintenance alarms:

1. With the unit shut down, move the Control Power switch to the ON (I) position. After initialization, the controller will toggle automatically to the Home screen.
2. Press \uparrow and \downarrow simultaneously to enter the navigation menu.
3. See Press \uparrow or \downarrow to move ✂ to the top of the screen. Press \checkmark to enter the Maintenance screen.
4. Press \uparrow or \downarrow to highlight the desired alarm that needs to be reset. Press \checkmark to start reset.
5. Enter the pin 4444. To do this, press \checkmark and then \uparrow or \downarrow to adjust the first number of the maintenance pin. Press \checkmark to continue to the next number.

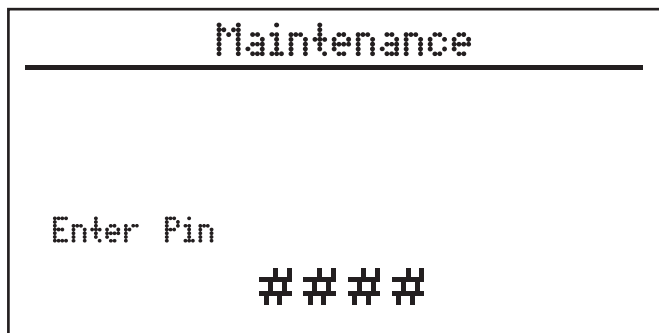

003784

Figure 4-1. Entering Maintenance Pin

Manual Winch: Use, Operation, and Maintenance

Prior to Use

- Inspect rope or cable and replace if damaged.
- Check mounting hardware for proper tightness and re-torque if necessary.
- Gears, ratchet pivot point and shaft bushings must be kept lubricated with a thin film of oil or grease.

Operation

Raising the Lights:

1. The cable must be securely fastened to the winch drum.

2. Verify the cable and cable attachments are not damaged. Contact Generac Mobile Products to order a replacement cable if necessary.
3. Referring to the "Lift / Let Down" decal on the winch, turn handle according to the specified direction to lift. The ratchet **MUST** make a loud clicking sound while winding the cable.

Lowering the Lights:

Referring to the "Lift / Let Down" decal on the winch, turn handle according to the specified direction to lower. No clicking will be heard because the brake system is activated.

Maintenance

The following procedures should be performed at least annually:

1. The gears and bushings of the winch must be kept lubricated. Apply a thin film of grease to the gear teeth, and oil the bushings as needed.
2. The ratchet pawl pivot point must be kept lubricated with a thin oil.

NOTE: Do not get oil or grease on the brake mechanism.

Electric Winch: Use, Operation, and Maintenance

- Keep the winch free of dirt, oil, grease, water and other substances.
- Check all mounting bolts and make sure they are tightened to the recommended torque values. Replace any damaged fasteners.
- Periodically check all connections to be sure they are tight and free of corrosion.
- Check the cable for visible damage every time the winch is operated. Examples of damage are: cuts, knots, crushed or frayed portions, and broken strands. Replace cable immediately if damaged. Failure to replace a damaged cable could result in breakage.
- Regularly check the brake for slippage or drift. This is detected visually when winch is under load. If winch drum continues to turn after controls are released, the brake may need to be replaced.
- Periodically clean and grease the brake assembly. This will ensure proper performance and extend the life of the winch. If winch seems to labor or get excessively hot during the lowering of loads, the brake will need to be serviced or replaced.
- Check motor brushes periodically and replace when necessary.

NOTE: Only the motor brushes and brake assembly require periodic replacement.

Winch Mechanical Brake

The mechanical brake generates heat when loads are lowered and the wire cable is powered out. Avoid overheating the mechanical brake. Overheating the mechanical brake may result in permanent damage to, or failure of, the brake. Replace any damaged brake components before resuming use of the winch.

Whine or chatter associated with a new mechanical brake is normal and typically disappears with use.

Overheating the mechanical brake may result in permanent damage to, or failure of, the brake. Replace any damaged brake components before resuming use of the winch.

Table 5: Winch Preventative Maintenance Schedule

Maintenance Activity	After First Operation	Before Each Use	Semi-Annually
Check Fasteners	◆		◆
Check Electrical Connections	◆		◆
Clean And Grease Brake Assembly			◆
Check Motor Brushes			◆
Visually Check Winch And Control	◆	◆	◆

Jack Maintenance

Before each use, check each jack foot for damage and remove any mud or debris. The jacks must be clean and in good operating condition to properly support the unit.

- Wipe any excess grease from the axle hub with a clean cloth and replace the rubber plug.

The minimum recommended lubrication is every 12 months or 12,000 miles (19,312 km). More frequent lubrication may be required under extremely dusty or damp operating conditions.

Trailer Wheel Bearings

The trailer axles are equipped with a Zerk grease fitting to allow lubrication of the wheel bearings without the need to disassemble the axle hub. Use only a high quality grease made specifically for lubrication of wheel bearings, such as Valvoline W615 or equivalent.

Every six months, or depending on usage, check for play in each bearing by jacking up the trailer, then trying to rock the wheel. If further assistance is required, contact Generac Mobile Products Technical Service at 1-800-926-9768.

See [Figure 4-2](#). To lubricate the wheel bearings:

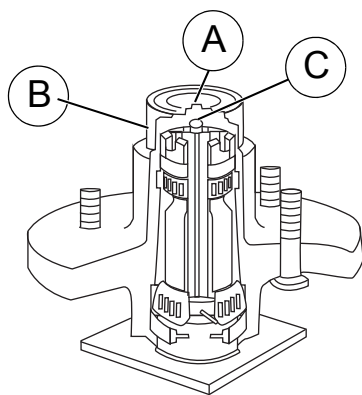

002540

Figure 4-2. Wheel Bearing Cross Section

- Remove the small rubber plug (A) from the metal end cap (B).
- Attach a standard grease gun fitting to the Zerk grease fitting (C).
- Pump grease into the Zerk fitting until fresh grease is visible around the nozzle of the grease gun.

This page intentionally left blank.

Section 5: Troubleshooting

General Troubleshooting

Some of the more common problems are listed in the table below. This information is intended to be a check or verification that simple causes can be located and fixed. It does not cover all types of problems. Refer to the OEM engine operator's manual for additional troubleshooting information. Procedures that require in-depth knowledge or skills should be referred to a Generac Mobile Products Authorized Service Dealer.



Risk of burns. Allow engine to cool before draining oil or coolant. Failure to do so could result in death or serious injury.

(000139)

Table 5-1. General Troubleshooting Guide

Problem	Possible Cause	Solution
Low oil pressure shutdown	Low oil level	Verify oil level on dipstick. Add oil, if needed.
	Oil leaking from engine	Visually inspect the engine for leaks.
	Oil pressure switch failure	Refer to OEM engine operator's manual to identify corrective action.
High coolant temperature shutdown	Low coolant level	Add coolant if needed. Allow engine to cool, then check coolant level in radiator. Restart engine and check coolant temperature. Stop engine immediately if coolant temperature is 210°F (99°C) or more.
	Blockage in radiator	Inspect radiator shroud and ducting for blockage and remove any foreign matter.
	Leakage in coolant hoses, engine block, or water pump	Inspect for visible leaks. Verify tension of water pump serpentine drive belt. Remove load on generator and restart engine. Verify coolant temperature and shut engine down immediately if it starts to overheat. Refer to the OEM engine operator's manual for additional information on engine overheating.
Unit cranks, but will not start	Fuel level low	Check fuel level in tank. Verify fuel pump operation.
	Restricted air filter	Inspect air filter for blockage. Refer to OEM engine operator's manual for additional information.

If problems continue, contact Generac Mobile Products at 1-800-926-9768 for assistance.

Troubleshooting the Lights



WARNING

Burn hazard. Lamps become extremely hot while in use. Allow 10–15 minutes for cooling before handling or lowering mast. Touching a hot lens or fixture can cause severe burns.
(000278)

IMPORTANT NOTE: Only a qualified electrician should troubleshoot or repair electrical problems occurring in this equipment. Contact Generac Mobile Products Technical Service at 1-800-926-9768 for assistance if you have any questions, or if problems persist.



WARNING

Electrocution. Potentially lethal voltages are generated by this equipment. Render the equipment safe before attempting repairs or maintenance. Failure to do so could result in death or serious injury.
(000187)

Problem	Possible Cause	Solution
Mast Lights Off, Checking Outside the Control Box	Light fixture is too hot	Allow light to cool 10-15 minutes before restarting.
	Faulty lamp connection	Check that the lamp is tight in the socket.
	Lamp broken	Check for broken arc tube or outer lamp jacket, broken or loose components in lamp envelope, or blackening/deposits inside tube.
	Loose lighting connections	Check the connections inside the mast junction box and each mast light housing/socket.
Mast Lights Off, Checking Inside the Control Box	Damaged or loose electrical cord	Check the mast electrical cord for damage and check the cord connections inside the control box.
	Loose lighting connections	Check the connections inside the control box and inside each ballast box.
	Generator output incorrect.	Check the incoming voltage to the ballast by checking the available voltage on the GFCI receptacle. Incoming voltage should be 120V +/- 5V. If voltage is incorrect, the engine speed may need to be adjusted or generator may require service.
Mast Lights On But the Light Output is Low	Low transformer output	The voltage from the transformer should read approximately 400VAC as the light “strikes” (induces an arc), then drop and slowly rise back up to stabilize at 240-260VAC. On hard wired models, remove the mast junction box cover and insert the wire probes into the connector blocks for the light and ground. If proper voltage is not achieved, perform capacitor check to determine if the capacitor or coil needs to be replaced.
	Fixture and/or lens is dirty	Clean reflective surface inside fixture and both inside and outside surface of glass lens. Use mild soap and water to clean lens. Other chemicals may have an adverse effect on the glass.
	Lamp worn due to normal use	Replace lamp.
	Damaged or loose electrical connections	Check the mast coil cord, mast junction box and mast light connections.
	Generator output incorrect	Check the incoming voltage to the ballast. Incoming voltage should be 120V +/-5V. If the voltage is incorrect, the engine speed may need to be adjusted or the generator may require service.
Low transformer output	The voltage from the transformer should read approximately 400VAC as the light “strikes” (induces an arc), then drop and slowly rise back up to stabilize at 240-260VAC. On hard wired models, remove the mast junction box cover and insert the wire probes into the connector blocks for the light and ground. If proper voltage is not achieved, perform capacitor check to determine if the capacitor or coil needs to be replaced.	

Section 6: Wiring Diagrams

Mast Junction Box Wiring and Light Connections

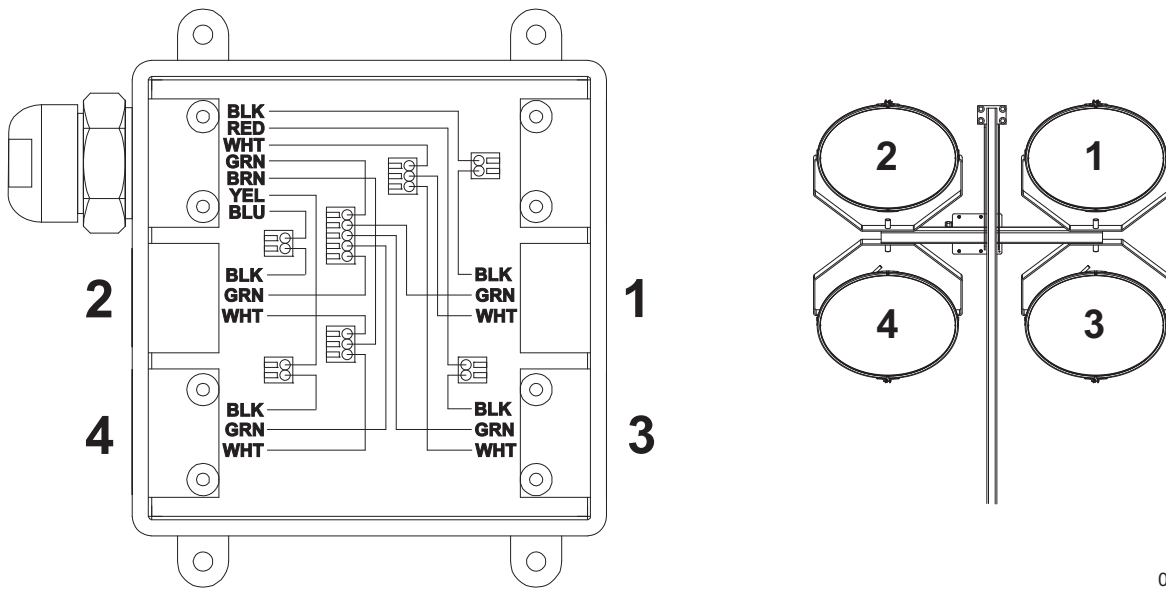

00768

AC Wiring Diagram

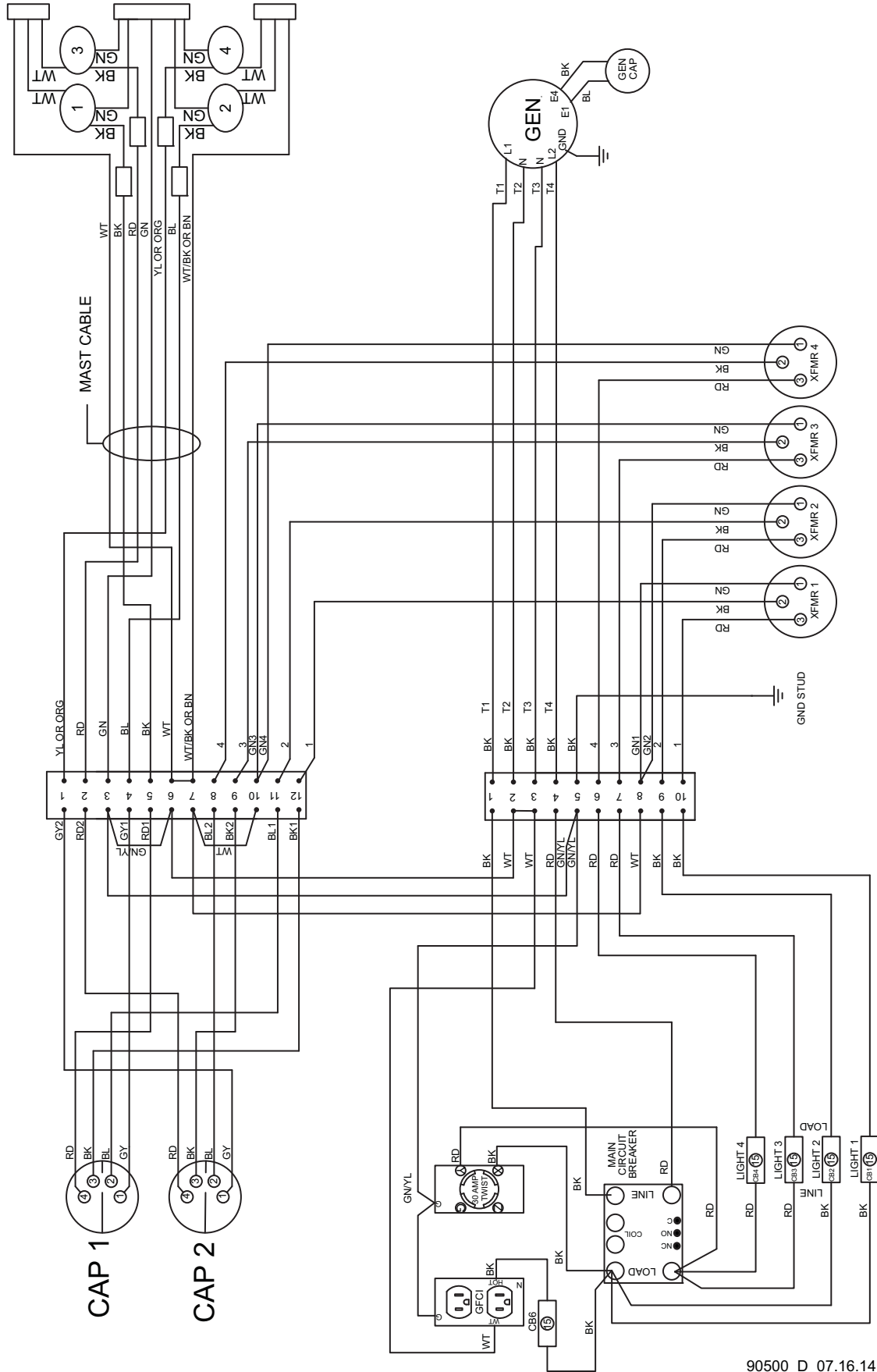

90500_D_07.16.14

DC Wiring Diagram

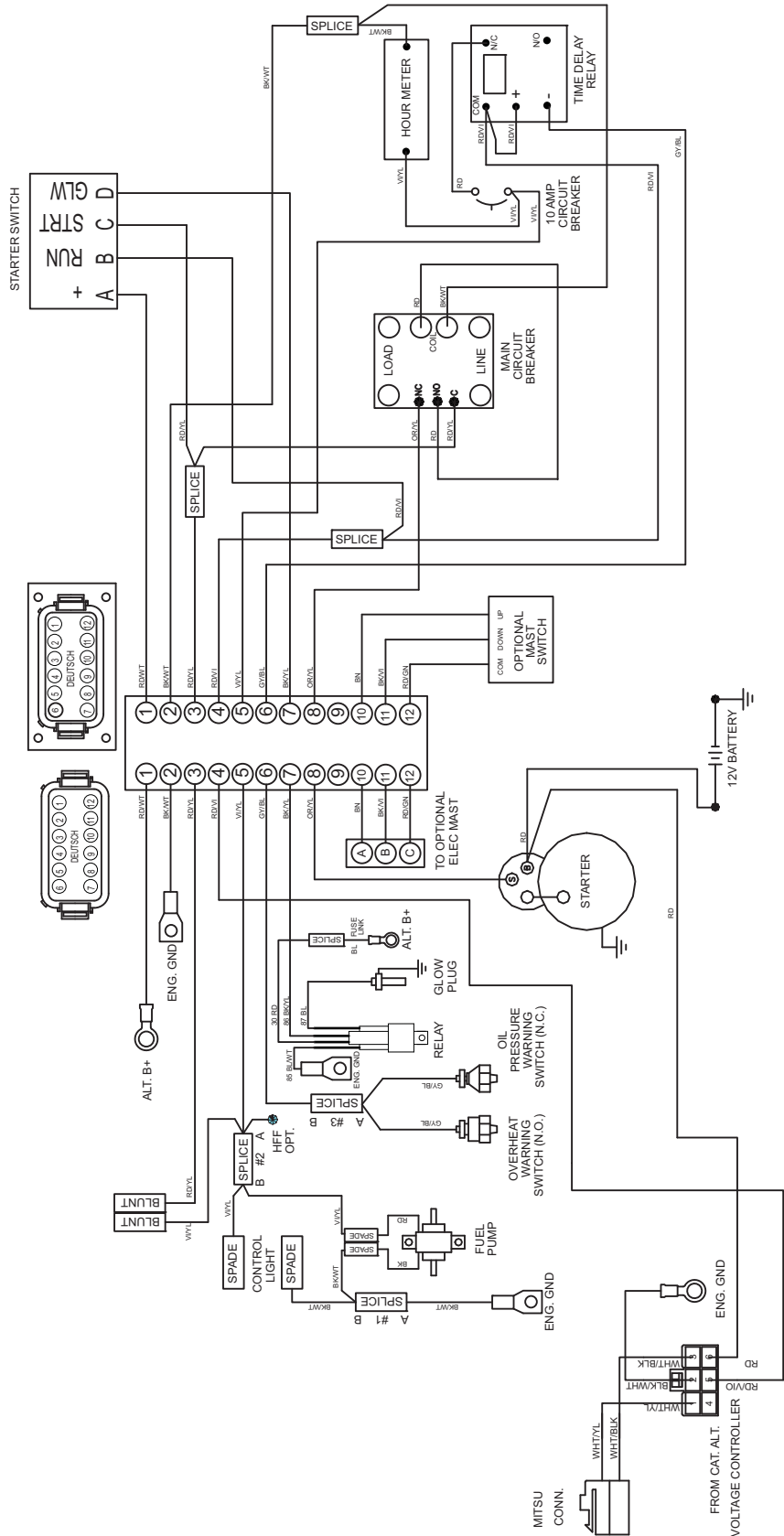

75008_B_03.18.16

DC Wiring - Electric Winch Option

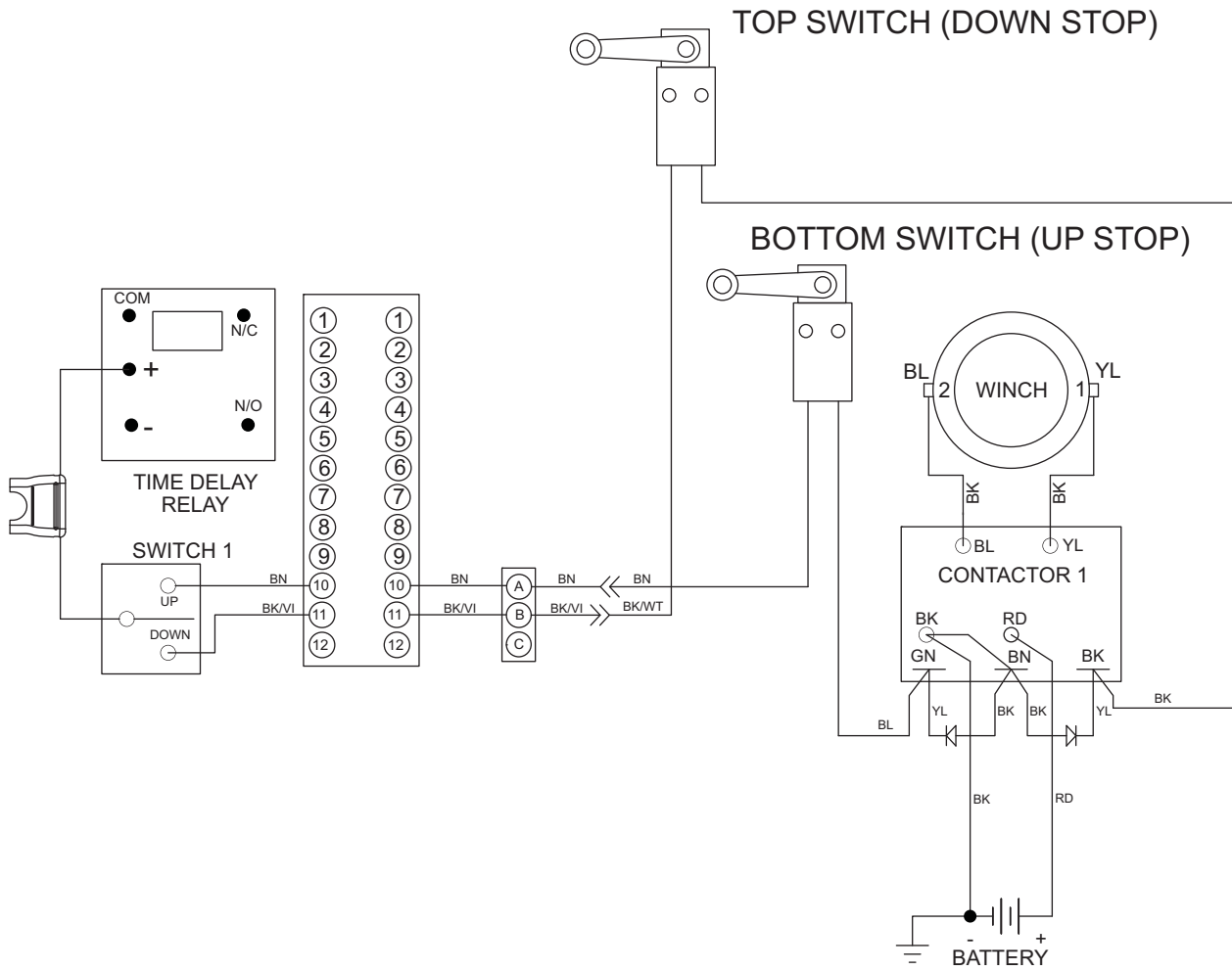

90596_A_07.19.16

Trailer Lights Wiring

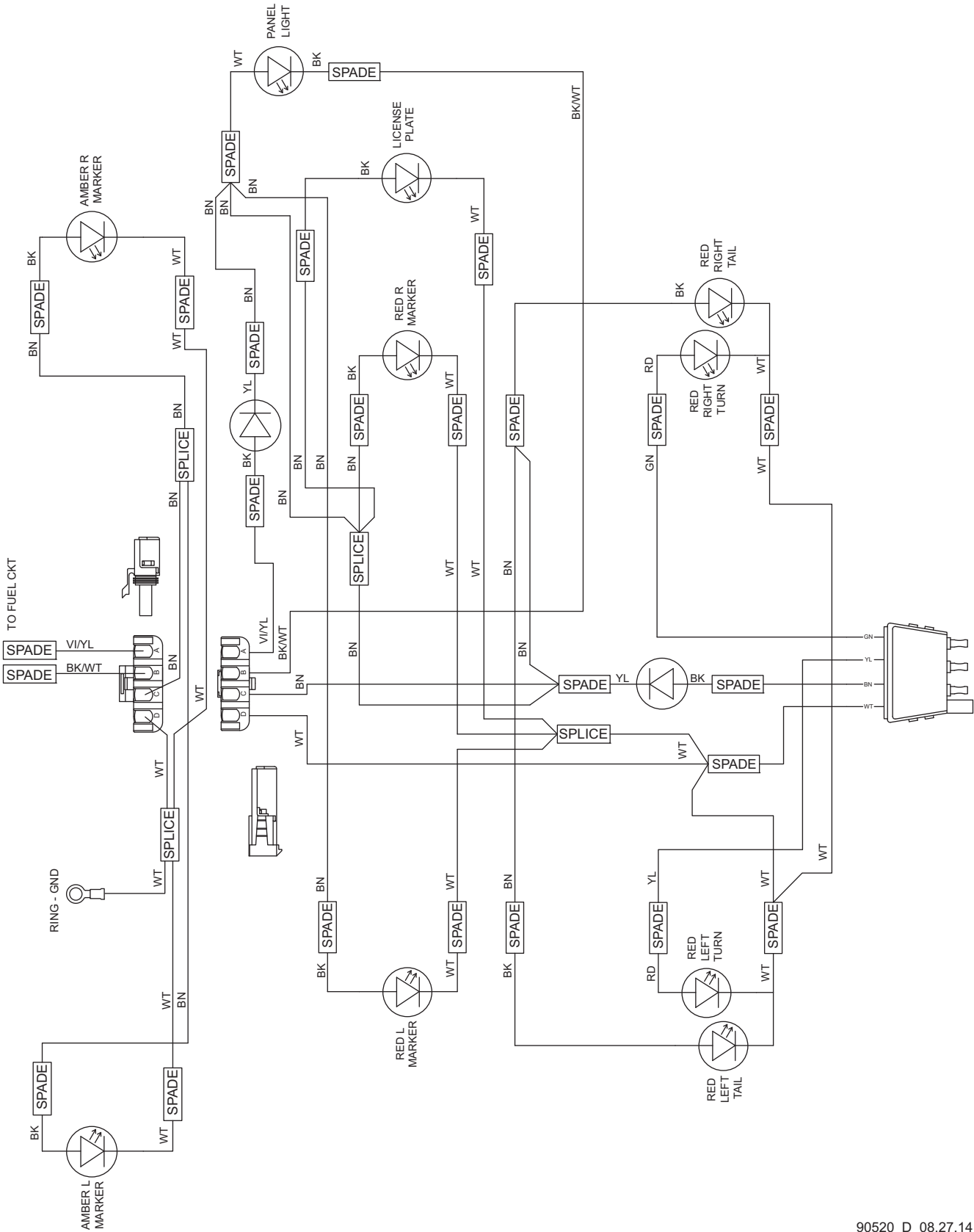

90520_D_08.27.14

This page intentionally left blank.

Section 7: Service Log

OIL GRADE: _____ BRAND: _____

COOLANT MIXTURE: _____ BRAND: _____

Date	Hours to Service	Oil Level	Coolant Level

Date	Hours to Service	Oil Level	Coolant Level

Part No. 21322 Rev. C 01/08/18
©2018 Generac Mobile Products, LLC
All rights reserved.

Specifications are subject to change without notice.
No reproduction allowed in any form without prior written
consent from Generac Mobile Products, LLC.

GENERAC

**MOBILE
PRODUCTS**

Generac Mobile Products, LLC
215 Power Drive, Berlin, WI 54923

GeneracMobileProducts.com | 800-926-9768 | 920-361-4442